

# iPECS

## iPECS-MG

---

# Hardware Description & Installation Manual

Please read this manual carefully before  
operating System. Retain it for future reference



## ***Regulatory Information***

Before connecting the iPECS-MG to the telephone network, you may be required to notify your local serving telephone company of your intention to use “customer provided equipment”. You may further be required to provide any or all of the following information:

PSTN line Telephone numbers to be connected to the system	Telephone Number
Model name	iPECS–MG
Local regulatory agency registration number	locally provided
Ringer equivalence	1.1
Registered jack	RJ–45

The required regulatory agency registration number is available from your local Ericsson-LG representative.

This equipment complies with the following regulatory standards, that is, the safety requirements of EN60950-1, UL 60950-1/CSA C22.2 No. 60950-1-03 and the EMC requirement of EN55022 and EN55024.

If the telephone company determines that customer provided equipment is faulty and may possibly cause harm or interruption in service to the telephone network, it should be disconnected until repair can be affected. If this is not done, the telephone company may temporarily disconnect service.

The local telephone company may make changes in its communications facilities or procedures. If these changes could reasonably be expected to affect the use of the iPECS-MG or compatibility with the network, the telephone company is required to give advanced written notice to the user, allowing the user to take appropriate steps to maintain telephone service.

The iPECS-MG complies with rules regarding radiation and radio frequency emission as defined by local regulatory agencies. In accordance with these agencies, you may be required to provide information such as the following to the end user.

## ***FCC Interference Statement***

### **Note**

This equipment has been tested and found to comply with the limits for a Class B digital device, pursuant to part 15 of the FCC Rules. These limits are designed to provide reasonable protection against harmful interference in a residential installation. This equipment generates, uses, and can radiate radio frequency energy and, if not installed and used in accordance with the instructions, may cause harmful interference to radio communications. However, there is no guarantee that interference will not occur in a particular installation. If this equipment does cause harmful interference to radio or television reception, which can be determined by turning the equipment off and on, the user is encouraged to try to correct the interference by one or more of the following measures:

- Reorient or relocate the receiving antenna.
- Increase the separation between the equipment and receiver.
- Connect the equipment into an outlet on a circuit different from that to which the receiver is connected.
- Consult the dealer or an experienced radio/TV technician for help.

Modifications not expressly approved by the manufacturer could void the user's authority to operate the equipment under FCC rules.

This device complies with part 15 of the FCC Rules. Operation is subject to the following two conditions:

- This device may not cause harmful interference, and this device must accept any interference received, including interference that may cause undesired operation.

## ***Compliance Statement for Canada***

This Class B digital apparatus complies with Canadian ICES-003.

Cet appareil numérique de la classe B est conforme à la norme NMB-003 du Canada.

## **[EU]**

### **European Union Declarations of Conformity**

Ericsson-LG Co., Ltd. declare that the equipment specified in this document bearing the "CE" mark conforms to the European Union Radio and Telecommunications Terminal Equipment Directive(R&TTE 1999/5/EC), including the Electromagnetic Compatibility Directive(2004/108/EC) and Low Voltage Directive(2006/95/EC).

Copies of these Declarations of Conformity (DoCs) can be obtained by contacting your local sales representative.

## **Warning**

This is a class A product. In a domestic environment this product may cause radio interference in which case the user may be required to take adequate measures.

**[USA/CSA]**

**FCC/IC Interference Statement**

This equipment has been tested and found to comply with the limits for a Class A digital device, pursuant to part 15 of the FCC Rules.

These limits are designed to provide reasonable protection against harmful interference when the equipment is operated in a commercial environment. This equipment generates, uses, and can radiate radio frequency energy and, if not installed and used in accordance with the instruction manual, may cause harmful interference to radio communications. Operation of this equipment in a residential area is likely to cause harmful interference in which case the user will be required to correct the interference at his own expense.

Change or modifications not expressly approved by the party responsible for compliance could void the user's authority to operate the equipment under FCC rules.

This device complies with part 15 /RSS-GEN of the FCC/IC rules. Operation is subject to the following two conditions:

(1) This device may not cause harmful interference; and (2) This device must accept any interference received, including interference that may cause undesired operation.

This Class A digital apparatus complies with Canadian ICES-003.

Cet appareil numérique de la classe A est conforme à la norme NMB-003 du Canada.

The use of this device in a system operating either partially or completely outdoors may require the user to obtain a license for the system according to the Canadian regulations.

**CAUTION :** Any changes or modifications in construction of this device which are not expressly approved by the party responsible for compliance could void the user's authority to operate the equipment.

***The following safety requirements are related to USA and Canada.***

**1. Replaceable batteries**

"CAUTION: Risk of Explosion if Battery is replaced by an Incorrect Type. Dispose of Used Batteries According to the Instructions."

**2. Separation of TNV and SELV - Pluggable A**

"The separate protective earthing terminal provided on this product shall be permanently connected to earth."

**3. Leakage currents due to ringing voltage - Earthing installation instructions**

- 1) A supplementary equipment earthing conductor is to be installed between the product or system and earth, that is, in addition to the equipment earthing conductor in the power supply cord.
- 2) The supplementary equipment earthing conductor may not be smaller in size than the unearthed branch-circuit supply conductors. The supplementary equipment earthing conductor is to be connected to the product at the terminal provided, and connected to earth

in a manner that will retain the earth connection when the power supply cord is unplugged. The connection to earth of the supplementary earthing conductor shall be in compliance with the appropriate rules for terminating bonding jumpers in Part K of Article 250 of the National Electrical Code, ANSI/NFPA 70 and Article 10 of Part 1 of the Canadian Electrical Code, Part 1, C22.1. Termination of the supplementary earthing conductor is permitted to be made to building steel, to a metal electrical raceway system, or to any earthed item that is permanently and reliably connected to the electrical service equipment earthed.

- 3) Bare, covered, or insulated earthing conductors are acceptable. A covered or insulated conductor must have a continuous outer finish that is either green, or green with one or more yellow stripes."

#### 4. Telephone line cord

"CAUTION: To reduce the risk of fire, use only No. 26 AWG or larger (e.g., 24 AWG) UL Listed or CSA Certified Telecommunication Line Cord".

#### 5. Rack Mount

- 1) Elevated Operating Ambient - If installed in a closed or multi-unit rack assembly, the operating ambient temperature of the rack environment may be greater than room ambient. Therefore, consideration should be given to installing the equipment in an environment compatible with the maximum ambient temperature ( $T_{ma}$ ) specified by the manufacturer.
- 2) Reduced Air Flow - Installation of the equipment in a rack should be such that the amount of air flow required for safe operation of the equipment is not compromised.
- 3) Mechanical Loading - Mounting of the equipment in the rack should be such that a hazardous condition is not achieved due to uneven mechanical loading.
- 4) Circuit Overloading - Consideration should be given to the connection of the equipment to the supply circuit and the effect that overloading of the circuits might have on overcurrent protection and supply wiring. Appropriate consideration of equipment nameplate ratings should be used when addressing this concern.
- 5) Reliable Earthing - Reliable earthing of rack-mounted equipment should be maintained. Particular attention should be given to supply connections other than direct connections to the branch circuit (e.g. use of power strips)."



#### **WARNING**

**“This equipment generates and uses R.F. energy, and if not installed and used in accordance with the Instruction Manual, it may cause interference to radio communications. It has been tested and found to comply with the appropriate limits for a telecommunication device. The limits are designed to provide reasonable protection against such interference, when operated in a commercial environment. Operation of this equipment in a residential area could cause interference, in which case the user, at his own expense, will be required to take whatever measures may be required to correct the interference.”**

## Revision History

ISSUE	DATE	CONTENTS OF CHANGES	REMARK
1.0	2009.12	Initial Release	
1.1	2012.12	General edits Updates for T1-PRI Added LDP DPB (Door Phone Box) Added BRIB Removed detailed Admin instructions Changed the new CI (Ericsson-LG)	

**Copyright© 2010 Ericsson-LG Co., Ltd. All Rights Reserved**

This material is copyrighted by Ericsson-LG Co., Ltd. (Ericsson-LG). Any unauthorized reproductions, use or disclosure of this material, or any part thereof, is strictly prohibited and is a violation of Copyright Laws. Ericsson-LG reserves the right to make changes in specifications at any time without notice. The information furnished by Ericsson-LG in this material is believed to be accurate and reliable, but is not warranted to be true in all cases.

**iPECS is trademark of Ericsson-LG Co., Ltd.**

All other brand and product names are trademarks or registered trademarks of their respective companies.

## ***Table of Contents***

<b>1. Introduction .....</b>	<b>1</b>
<b>1.1 Important Safety Instructions.....</b>	<b>1</b>
1.1.1 Safety Requirements.....	1
<b>1.2 Precaution.....</b>	<b>2</b>
1.2.1 Caution .....	2
1.2.2 Disposal of Old Appliance .....	3
<b>1.3 Manual Use.....</b>	<b>3</b>
<b>2. System Overview .....</b>	<b>4</b>
<b>2.1 iPECS-MG System Highlights .....</b>	<b>4</b>
<b>2.2 System Connection Diagram.....</b>	<b>5</b>
<b>2.3 System Components.....</b>	<b>6</b>
<b>2.4 General Specifications.....</b>	<b>7</b>
2.4.1 Dimension and Weight .....	7
2.4.2 Environment .....	7
2.4.3 System Electrical.....	7
2.4.4 PSU Fan.....	8
2.4.5 DECT Base Station (GDC-400B/GDC-600B/GDC-600BE).....	8
2.4.6 Station Distance from the System.....	8
2.4.7 CO Loop .....	9
2.4.8 Wireless DECT Terminal.....	9
2.4.9 MPB VOIP .....	9
2.4.10 VOIP channels (VOIB) .....	10
2.4.11 Other System Specifications .....	10
<b>2.5 System Capacity.....</b>	<b>11</b>
2.5.1 System Maximum Call Capacity .....	12
<b>3. Installation Overview .....</b>	<b>14</b>
<b>3.1 General Installation Procedure .....</b>	<b>14</b>
<b>3.2 Types of Connectors.....</b>	<b>14</b>
<b>3.3 Installation and Safety Precautions .....</b>	<b>16</b>
<b>4. KSU Installation .....</b>	<b>17</b>

---

<b>4.1 BKSU Unpacking</b> .....	<b>17</b>
<b>4.2 EKSU Unpacking</b> .....	<b>18</b>
<b>4.3 KSU Diagram, Exterior and Dimension</b> .....	<b>19</b>
<b>4.4 Basic KSU Mounting</b> .....	<b>20</b>
4.4.1 Rack Mounting .....	20
4.4.2 Wall Mounting.....	21
<b>4.5 Expansion KSU Installation</b> .....	<b>23</b>
<b>4.6 Power Supply Unit Wiring</b> .....	<b>26</b>
4.6.1 Frame Ground Connection.....	26
4.6.2 External Backup Battery Installation .....	27
4.6.3 Power Supply Unit Replacement .....	28
<b>5. BOARD INSTALLATION</b> .....	<b>30</b>
<b>5.1 General Board Install Procedure</b> .....	<b>30</b>
<b>5.2 Main Processing Board</b> .....	<b>31</b>
5.2.1 Switch and LED Functions .....	32
5.2.2 Modem Unit Installation.....	34
5.2.3 MPB Installation .....	34
5.2.4 LAN Port Wiring.....	34
5.2.5 Connecting Miscellaneous Devices .....	35
5.2.5.1 Alarm/Relay Wiring .....	35
5.2.5.2 Page Audio Connector Wiring .....	36
5.2.5.3 MOH Connector Wiring .....	36
5.2.6 USB Connector .....	36
5.2.7 RS-232 Monitor Wiring.....	37
5.2.8 DSIU (Digital and Single Line Interface Unit) Wiring .....	38
<b>5.3 CO Line Boards</b> .....	<b>39</b>
5.3.1 LCOB (Loop Start CO Line Interface Board) .....	39
5.3.1.1 CMU (Call Metering Unit) Installation .....	40
5.3.1.2 LCOB Installation.....	40
5.3.1.3 LCOB Wiring.....	41
5.3.2 BRIB (Basic Rate Interface Board) w/Selectable S/T Interface .....	42
5.3.2.1 Switch and LED Functions .....	44
5.3.2.2 BRIB Installation .....	46
5.3.2.3 BRIB Wiring .....	46
5.3.2.4 Serial Port.....	47
5.3.3 E1R2-PRIB (Primary Rate Interface Board) .....	48
5.3.3.1 Switch and LED Functions .....	49
5.3.3.2 E1-PRIB Installation.....	49
5.3.3.3 E1-PRIB Wiring .....	50
5.3.3.4 Serial Port.....	50
5.3.4 T1-PRIB (Primary Rate Interface Board) .....	51

---



---

5.3.4.1 Switch and LED Functions .....	52
5.3.4.2 T1-PRIB Installation.....	52
5.3.4.3 T1-PRIB Wiring.....	53
5.3.4.4 Serial Port.....	53
<b>5.4 Extension Boards .....</b>	<b>54</b>
5.4.1 SLIB (Single Line Interface Board w/RJ45) .....	54
5.4.1.1 LED Functions .....	55
5.4.1.2 SLIB Installation.....	55
5.4.1.3 SLIB Wiring.....	56
5.4.2 SLIBC (Single Line Interface Board w/RJ21).....	57
5.4.2.1 LED Functions .....	59
5.4.2.2 SLIBC Installation .....	60
5.4.2.3 SLIBC Wiring .....	60
5.4.3 DTIB (Digital Terminal Interface Board w/RJ-45).....	62
5.4.3.1 LED Functions .....	63
5.4.3.2 DTIB Installation .....	63
5.4.3.3 DTIB Wiring .....	63
5.4.4 DTIBC (Digital Telephone Interface Board w/RJ21 connector) .....	64
5.4.4.1 LED Functions .....	65
5.4.4.2 DTIBC Installation.....	66
5.4.4.3 DTIBC Wiring.....	66
5.4.5 WTIB (Wireless Telephone Interface Board) for DECT .....	68
5.4.5.1 Connectors, Switch and LED Functions .....	71
5.4.5.2 DECT Installation.....	72
5.4.5.3 WTIB Installation.....	72
5.4.5.4 Ferrite Core Installation .....	72
5.4.5.5 WTIB Wiring .....	73
5.4.5.6 Serial Port.....	74
<b>5.5 Function Boards .....</b>	<b>75</b>
5.5.1 VMIB (Voice Mail Interface Board) and AAIB (Auto-Attendant Interface Board) .....	75
5.5.1.1 Switch, and LED Functions .....	76
5.5.1.2 VMIB and AAIB Installation.....	76
5.5.1.3 VMIB and AAIB Wiring .....	76
5.5.1.4 VMIB and AAIB LAN Connector .....	77
5.5.1.5 Serial Port.....	77
5.5.2 VOIB (Voice over Internet protocol Board, 8 and 24channel).....	78
5.5.2.1 Switch and LED Functions .....	78
5.5.2.2 VOIB Installation .....	79
5.5.2.3 VOIB Wiring.....	79
5.5.2.4 Serial Port.....	79
<b>5.6 Serial to Audio Cable Specification .....</b>	<b>80</b>
5.6.1 Serial to Audio Cable Wiring .....	80
<b>5.7 Cable Dressing .....</b>	<b>81</b>
5.7.1 Wall Mount Wiring .....	81
5.7.2 Rack Mount Wiring.....	82

---

<b>6. TERMINAL CONNECTION AND WIRING .....</b>	<b>83</b>
<b>6.1 Terminal and Door Phone Models .....</b>	<b>83</b>
6.1.1 Terminal Cabling Distance .....	87
6.1.2 Terminal Connections .....	87
6.1.2.1 DKT Wiring .....	87
6.1.2.2 SLT wiring.....	88
6.1.2.3 LIP-7000 & LIP-8000 & 8000E Series Keypad Wiring.....	88
6.1.3 LDP Door Phone Box.....	89
6.1.3.1 Door Phone Box Installation .....	89
6.1.3.2 Door Phone Box Wiring .....	89
6.1.4 DSS/BLF Console Installation & Wiring .....	91
6.1.4.1 LDP-7048 DSS Install.....	91
6.1.4.2 LDP-7048 and LIP-7048 DSS Console Wiring .....	91
6.1.4.3 LIP-8000 DSS Installation and Wiring .....	91
6.1.5 Wall Mount .....	95
6.1.5.1 LDP-7000 and LIP-7000 Wall Mounting .....	95
6.1.5.2 LIP-8000 & 8000E Wall Mounting .....	95
<b>7. STARTING THE IPECS-MG .....</b>	<b>97</b>
<b>7.1 Initializing Databases .....</b>	<b>97</b>
<b>8. TROUBLESHOOTING .....</b>	<b>100</b>
<b>9. APPENDIX. USEFUL INFORMATION .....</b>	<b>102</b>

---

# 1. INTRODUCTION

---

## 1.1 Important Safety Instructions

---

### 1.1.1 Safety Requirements

When using your telephone equipment, basic safety precautions should always be followed to reduce the risk of fire, electric shock and other personal injury, including the following:

- Please read and understand all instructions.
- Follow all warnings and instructions marked on the product.
- Unplug this product from the wall outlet before cleaning; a damp cloth should be used for cleaning, do not use liquid or aerosol cleaners.
- Do not use this product near water, such as a bathtub, washbowl, kitchen sink, or laundry tub, in a wet basement, or near a swimming pool.
- Do not place this product on an unstable table, stand, or card table; the product may fall, causing serious damage to the product or serious injury to those nearby.
- Slots and openings in the KSU and the back or bottom are provided for ventilation, to protect from overheating, these openings must not be blocked or covered. The openings should never be blocked by placing the product on a bed, sofa, or other similar surface. This product should never be placed near or over a radiator or other heat source. This product should not be placed in a built-in installation without proper ventilation.
- This product should be operated only from the type of power source indicated on the product label. If you are not sure of the type of power supply at your location, consult your dealer or local power company.
- Do not allow anything to rest on the power cord. Do not locate this product where the cord could be abused by people walking on it.
- Do not overload wall outlets and extension cords as this can result in the risk of fire or electric shock.
- Never push objects of any kind into this product through KSU slots or connectors as they may touch dangerous voltage points or short out parts that could result in a risk of fire or electric shock.
- Never spill liquid of any kind on the product.
- To reduce the risk of electric shock, do not disassemble this product. Instead, take it to a qualified person when service or repair work is required. Opening or removing covers may expose you to dangerous voltages or other risk. Incorrect reassemble can cause electric shock when the appliance is subsequently used.
- Unplug this product from the wall outlet and refer servicing to qualified service personnel under the following conditions:
  - When the power supply cord or plug is damaged or frayed.
  - If liquid has been spilled into the product
  - If the product has been exposed to rain or water
  - If the product does not operate normally by following the operating instructions. Adjust only those controls that are covered by the operating instructions because

- improper adjustment of other controls may result in damage and will often require extensive work by a qualified technician to restore the product to normal operation.
- If the product has been dropped or the KSU has been damaged.
  - If the product exhibits a distinct change in performance
  - Avoid using a telephone during an electrical storm; there is a remote risk of electric shock and serious injury from lightning.
  - In the event of a gas leak, do not use the telephone near the leak.

---

## 1.2 Precaution

---

- Keep the system away from heating appliances and electrical noise generating devices such as florescent lamps, motors and televisions. These noise sources can interfere with the performance of the iPECS-MG System.
- This system should be kept free of dust, moisture, high temperature (more than 40 degrees) and vibration, and should not be exposed to direct sunlight.
- Never attempt to insert wires, pins, etc. into the system. If the system does not operate properly, the equipment should be repaired by an authorized Ericsson-LG service center.
- Do not use benzene, paint thinner, or an abrasive powder to clean the KSU. Wipe it with a soft cloth only.

### 1.2.1 Caution

- This system should only be installed and serviced by qualified service personnel.
- When a failure occurs which exposes any internal parts, disconnect the power supply cord immediately and return this system to your dealer.
- To prevent the risk of fire, electric shock or energy hazard, do not expose this product to rain or any type of moisture.
- To protect PCB from static electricity, discharge body static before touching connectors and/or components by touching ground or wearing a ground strap.



#### **WARNING**

If the battery is not correctly replaced, it may explode.  
Replace only with the same or equivalent type recommended by the manufacturer.  
Dispose of used batteries according to the manufacturer's instructions

---

## 1.2.2 Disposal of Old Appliance

When the displayed symbol (crossed-out wheeled bin) is adhered to a product, it designates the product is covered by the European Directive 2002/96/EC.



- All electric and electronic products should be only be disposed of in special collection facilities appointed by government or local/municipal authorities.
- The correct disposal of your old appliance will help prevent potential negative consequences for the environment and human health.
- For more detailed information about disposal of your old appliances, please contact your city office, waste disposal service or the place of product purchase.

---

## 1.3 Manual Use

This document provides general information covering the hardware description and installation of the iPECS-MG System. While every effort has been taken to ensure the accuracy of this information Ericsson-LG Co., Ltd. makes no warranty of accuracy or interpretations thereof.

- [Section 2 System Overview](#)  
General information on the iPECS-MG System, including system specifications and capacity.
- [Section 3. Installation Overview](#)  
Overview for general installation procedures, precautions and connectors.
- [Section 4 KSU Installation](#)  
Instructions for installation of the iPECS-MG cabinets.
- [Section 5 Board Installation](#)  
Detailed instructions for installing and wiring components of the iPECS-MG Board.
- [Section 6 Terminal Connection and Wiring](#)  
Description of terminals, wiring distance, and terminal wiring connections.
- [Section 7 Starting iPECS-MG System](#)  
Describes procedures to default the iPECS-MG system database in preparation for Admin configuration.
- [Section 8 Troubleshooting](#)  
Explains common troubleshooting issues.

## 2. SYSTEM OVERVIEW

---

### 2.1 iPECS-MG System Highlights

---

Features of the iPECS-MG System include:

- Flexible System Capacity and architecture
- Minimum daughter board
- Powerful PC application, Remote maintenance via LAN/Modem/RS-232C, Web Admin
- Stable & Enhanced voice features
- Simple installation & efficient system management
- Value-Added features
  - Distinctive and Enhanced Voice Mail Function and Multi Language
  - Basic CID [FSK,DTMF, RUS CID] Function for CO & SLT
  - Basic 4 AA Function(default) or 4 VoIP channel and 6 DKT + 6 SLT ports on MPB
  - Built in PLL Circuit for ISDN Clock Synchronization, No need cabling
  - 8 Poly internal MOH (13 Music resources)
  - PSTN/SLT Line Monitoring function for maintenance
  - Green Product (DKT/SLT Power save mode by program, Low EMI , PB-Free product)

## 2.2 System Connection Diagram

The following [Figure 2.2-1](#) System Connection Diagram shows the components that make up the iPECS-MG solution:

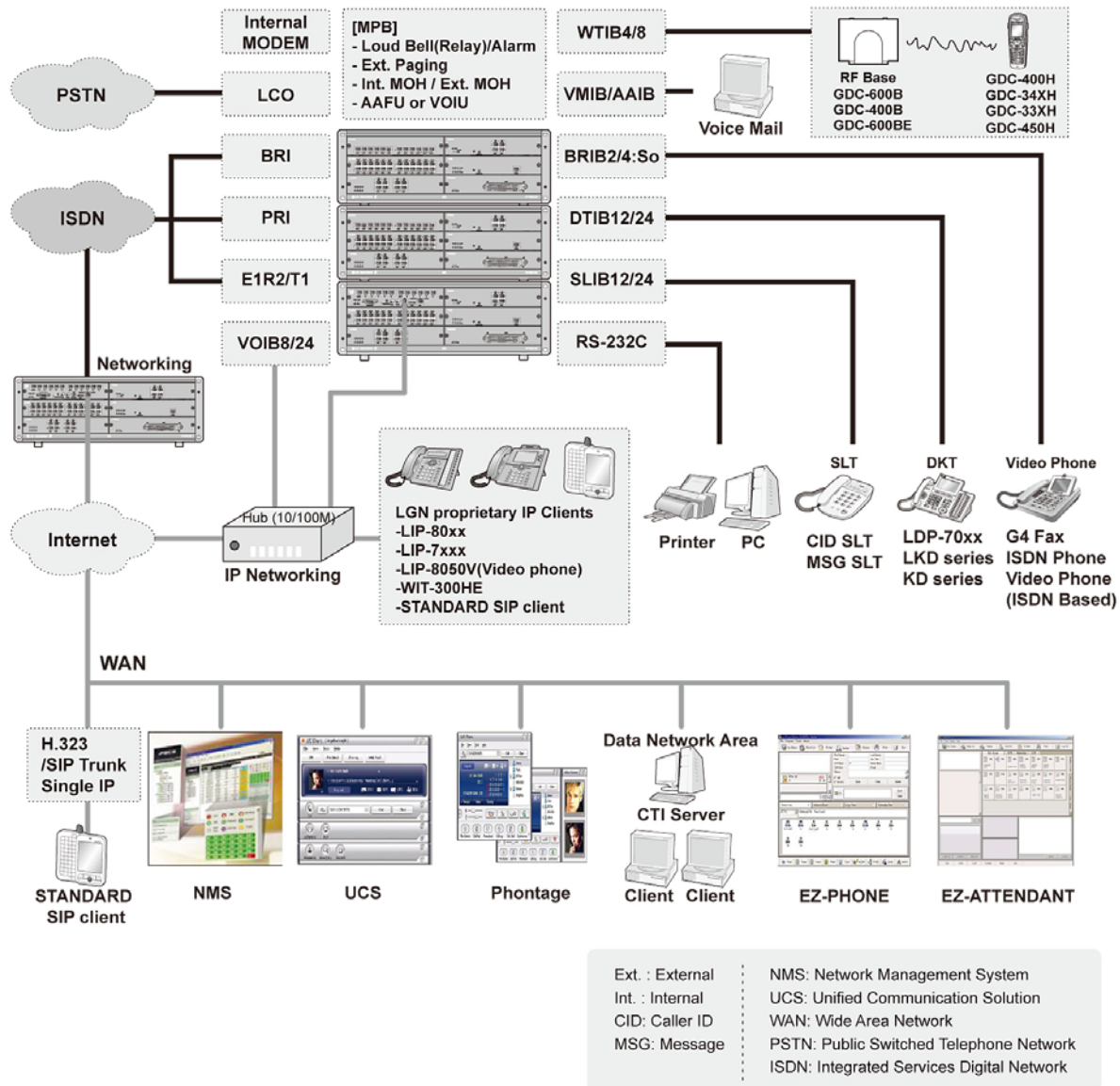

Figure 2.2-1 System Connection Diagram

## 2.3 System Components

ITEM		OPTION BOARD	DESCRIPTION
<b>BKSU</b>			Basic KSU
<b>EKSU</b>			Expansion KSU
<b>PSU</b>			Power Supply Unit (350W)
<b>Main Board</b>	<b>MPB100</b>		Main Processor Board 100 w/6 DKT, 6 SLT
		MODU	Modem Unit
	<b>MPB300</b>		Main Processor Board 300 w/6 DKT, 6 SLT
		MODU	Modem Unit
<b>Trunk Boards</b>	<b>LCOB4</b>	CMU4	4 LCO Interface Board
	<b>LCOB8</b>	CMU8	8 LCO Interface Board
	<b>LCOB12</b>	CMU12	12 LCO Interface Board
	<b>E1/PRIB</b>		Digital CO Interface Board (1 PRI or 1 E1R2)
<b>Extension Boards</b>	<b>SLIB12</b>		12 SLT Interface Board
	<b>SLIB12C</b>		12 SLT Interface Board (RJ21)
	<b>SLIB24</b>		24 SLT Interface Board
	<b>SLIB24C</b>		24 SLT Interface Board (RJ21)
	<b>DTIB12</b>		12 DKT Interface Board
	<b>DTIB12C</b>		12 DKT Interface Board (RJ21)
	<b>DTIB24</b>		24 DKT Interface Board
	<b>DTIB24C</b>		24 DKT Interface Board (RJ21)
<b>Function Boards</b>	<b>WTIB</b>		Voice Mail Interface Board (8 channels, 100 hrs)
	<b>AAIB</b>		Auto Attendant Interface Board (8 channels)
	<b>VOIB8</b>		8 channel VoIP Interface Board
	<b>VOIB24</b>		24 channel VoIP Interface Board
<b>DETC</b>	<b>GDC-600B</b> <b>GDC-600BE</b>		DECT Base Station (6 channels per Base)
	<b>WTIB4</b>		4 channel DECT Wireless Terminal Interface Board
	<b>WTIB8</b>		8 channel DECT Wireless Terminal Interface Board
	<b>WMK</b>		Wall Mount Bracket



## 2.4 General Specifications

### 2.4.1 Dimension and Weight

ITEM		HEIGHT (mm)	WIDTH (mm)	DEPTH (mm)	WEIGHT (kg)
BKSU		170.2	440	325.4	6.2
EKSU		170.2	440	325.4	6.25
Digital Keypad*		268	203	124	0.9
Digital DSS/DLS Console		154	175	111	0.4
Digital ICM/Door Box		32	132	99	0.5
Digital Data Module		37	175	148	1.5
Base Station (600B/ 600BE)		170	220	57	0.46
Wireless Terminal	GDC-33xH	145	50	35	0.15
	GDC-34xH	131	49	32	0.102
	GDC-4xxH	133	44	20	0.92

\* Digital Keypad: LDP-7024D, Digital DSS: LDP-7048DSS, Digital Door Box: LDP-DPB

### 2.4.2 Environment

ITEM	DEGREES (°C)	DEGREES (°F)
Operation Temperature	0–40	32–104
Optimum Operation Temperature	20–26	68–78
Storage Temperature	10–70	32–158
Relative Humidity	0–80% non-condensing	

### 2.4.3 System Electrical

ITEM	SPECIFICATION (PSU)
1. Power Supply	
– AC Voltage Input	100–240 Volt AC @47–63Hz
– AC Power	350W
– AC Input Fuse	6.3A @ 250Volt AC
– DC Output Voltage	+ 5, + 30Volt DC
2. Battery Backup	
–PSU Input Voltage	24Volt DC
–PSU Battery Fuse	15.0A @250Volt AC
–Charging Current	Max. 1A

## 2.4.4 PSU Fan

ITEM	SPECIFICATION
Maker / part number	POWERLOGIC / PLA07015B05H
Dimensions	70 X 70 X 15 (mm)
Rated voltage	+5V

## 2.4.5 DECT Base Station (GDC-400B/GDC-600B/GDC-600BE)

ITEM	SPECIFICATION
Power feeding	+30V DC
Transmission Max. Power	250mW
Access Method/Duplex	TDMA/TDD
Frequency Band	1, 880–1, 900MHz
Channel Spacing	1.728MHz
Modulation	GFSK
Data rate	1.152Mbps
Max. Base Station distance from the WTIB	600m (twisted 2-pair cable)

## 2.4.6 Station Distance from the System

ITEM	22 AWG Wire (m/kft)	24 AWG Wire (m/kft)
Digital Keypad	500 / 1.6	330 / 1
Single Line Telephone	7, 500 / 24.6	5, 000 / 16.5

## 2.4.7 CO Loop

ITEM	SPECIFICATION
Ring Detect Sensitivity	30Vrms @20–50Hz
DTMF Dialing	
Frequency Deviation	Less than +/- 1.8 %
Signal Rise Time	Max. 5ms
Tone Duration, on time	Min. 50ms
Inter-digit Time	Min. 30ms
Pulse Dialing	
Pulse Rate	10 pps
Break/Make Ratio	60/40%, 66/33% or 50/50%

## 2.4.8 Wireless DECT Terminal

ITEM	SPECIFICATION
Max. Transmission Power	250mW
Modulation Method	GFSK
Frequency Band	1, 880MHz–1, 900MHz

## 2.4.9 MPB VOIP

ITEM	SPECIFICATION
LAN Interface	10 / 100 Base-T Ethernet (IEEE 802.3)
Speed	10 Mbps or 100 Mbps (Auto-Negotiation)
Duplex	Half Duplex or Full Duplex (Auto-Negotiation)
VoIP Protocol	SIP (RFC3261) and H.323 Revision 2
Voice Compression	G.711/G.729/G.723.1
Voice/Fax Switching	T.38
Echo cancellation	G.168

## 2.4.10 VOIP channels (VOIB)

ITEM	SPECIFICATION
LAN Interface	10 / 100 Base-T Ethernet (IEEE 802.3)
Speed	10 Mbps or 100 Mbps (Auto-Negotiation)
Duplex	Half Duplex or Full Duplex (Auto-Negotiation)
VoIP Protocol	SIP (RFC3261) and H.323 Revision 2
Voice Compression	G.711/G.729/G.723.1
Voice/Fax Switching	T.38
Echo cancellation	G.168

## 2.4.11 Other System Specifications

ITEM	DESCRIPTION	SPECIFICATION
CPU		M82805G, ARM9 Dual core (32bit, 375MHz)
Switching Device		ACT2, Custom Mixed-Signal ASIC Device
Memory Back-up Duration		7years
Ring Signal		70Vrms, 25Hz
External Relay Contact		1A @30Volt DC
External Music Port		0dBm @600ohm
External Paging Port		0dBm @600ohm
MODU	Analog Modem	Bell, ITU-T, V.34 V.32BIS, V.90
	Speed	300bps up to 33Kbps speed rate
	Connection	Automatic rate negotiation
USB	Version	USB 1.1 compliant
	Speed	Max. 12Mbps
	Mode	Host Mode (Memory stick) only

## 2.5 System Capacity

DESCRIPTION	CAPACITY/BOARD	TOTAL
Time Slots		144 per KSU, Total Max. 432
Max. Ports		200 (MPB100), 414 (MPB300)
CO Line Ports		80 (MPB100) , 240 (MPB300)
Max. Direct Station (DKT, SLT, DSS, So) Connections		120 (MPB100), 324 (MPB300)
LAN Port	1/MPB, 1/VOIB8, VOIB24 1/VMIB, AAIB	1
MODEM Channel	1/MODU	1
Attendant Positions	5/Tenant	
Tenant Group	5 (MPB100), 9 (MPB300)	
Intercom Links	Non-Blocking	
Paging – All Call – Internal		1 zone 15 zones (MPB100) 30 zones (MPB300)
Station Speed Dial	50 (32 digits) / Station	
System Speed Dial		1000 (32 digits) (MPB100) 2000 (32 digits) (MPB300)
Call Log (Outgoing/Incoming/Missed Call)		100 (32 digits) (Not Protected)
CO Line Group		24 (MPB100) 72 (MPB300)
Station Group		20 (50 members/group, MPB100) 50 (50 members/group, MPB300)
Conference	3–13 Party	All ports are available
Multi-Conference	3–13 Party	Max. 3 groups / 13 party
Internal MOH (13 Music Resources)	1/MPB	1
External MOH	1/MPB	1
External Paging port	1/MPB	1
External Relay Contact	1/MPB	1
Alarm Input	1/MPB	1
RS-232C Port	1/MPB, 1/IPP Board	1
USB Port	1/MPB, 1/VMIB, AAIB	1 Host mode (Memory stick) only
CPT/CID/ CO DTMF Detection channels	32 channels (MPB100), 64 channels (MPB300)	32 channels (MPB100), 64 channels (MPB300)
PFT Circuit	1/LCOB4, LCOB8, LCOB12	

## 2.5.1 System Maximum Call Capacity

iPECS-MG, MPB100	MAXIMUM PORT					
	EXTENSION		TRUNK			
	SO	DKTU/SLT	PRI	BRI	CO	IP
1 <sup>st</sup> KSU	40	102*1	80	40	60	80
Total	108		80			
	120					
1 <sup>st</sup> KSU + 2 <sup>nd</sup> KSU	88	120	80	80	80	80
Total	120		80			
	200					

- \*1 DSIU DKT 6 + DTIB24, 4ea
- Max. DECT Terminal registration : 96
  - Max. IP Phone registration : 120
  - Max. VMIB or AAIB : 2each
  - Max. WTIB : 2each

iPECS-MG, MPB300	MAXIMUM PORT					
	EXTENSION		TRUNK			
	SO	DKTU/SLT	PRI	BRI	CO	IP
1 <sup>st</sup> KSU	40	102*1	120	40	60	120
Total	108*2		120			
	138					
1 <sup>st</sup> KSU + 2 <sup>nd</sup> KSU	88	198	180	88	132	180
Total	216		180			
	276					
1 <sup>st</sup> + 2 <sup>nd</sup> + 3 <sup>rd</sup> KSU	136	294	240	136	204	240
Total	324		240			
	414					

- \*1 DSIU DKT/SLT 6 + (4) DTIB24/SLIB24
- \*2 DSIU DKT 6 + DSIU SLT 6 + (4) DTIB24/SLIB24
  - Max. DECT Terminal registration : 192
  - Max. IP Phone registration : 324
  - Max. VMIB or AAIB : 3each
  - Max. WTIB : 3ea
  - Max. WTIB: 3 each, when installing more than one WTIB4/8, install all WTIB4/8 in the same KSU
  - If installed ports exceed capacity, the attendant keyset receives an alarm.

**Table 2.5.1-1 Simplified Maximum Port Chart**

Boards	Max. Extension			Max. Trunk	TOTAL
	Total	IP / TDM	DECT		
MPB100	120	120	96	80	<b>200</b>
MPB300	324	324	192	240	<b>414</b>

## 3. INSTALLATION OVERVIEW





### 3.1 General Installation Procedure

The basic steps to install an iPECS-MG are:

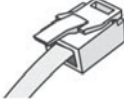
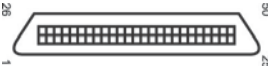

1. Locate the area for installing the system
2. Verify all equipment for the installation is on-site
3. Install the Basic and Expansion cabinets
4. Install the various boards in the cabinets
5. Wire the boards to the appropriate termination points
6. Wire and connect terminals
7. Initial power-up to default the database
8. Configure the system, see iPECS Feature and Admin Manuals
9. Verify the installation.

### 3.2 Types of Connectors

The following chart displays the various types of connectors employed with the iPECS-MG and the various boards.

iPECS-MG CONNECTOR TYPE	MATING-CONNECTOR	BOARD	PURPOSE
RJ11 		MPB	Relay and Alarm Port
RJ45 		MPB, VOIB8, VOIB24, VMIB, AAIB, WTIB4, WTIB8. DSIU, DTIB12, DTIB24, SLIB12, SLIB24 LCOB4, LCOB8, LCOB12 PRIB, BRIB4, BRIB8	LAN Port Telephony Ports DKT Ports SLT Ports LCO Ports ISDN channels
RJ21 (Female) 	(Male) 	DTIB12C, DTIB24C SLIB12C, SLIB24C	DKT Ports SLT Ports

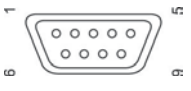
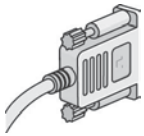

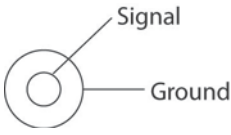
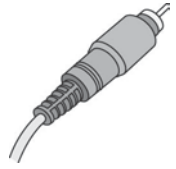
<b>iPECS-MG CONNECTOR TYPE</b>	<b>MATING-CONNECTOR</b>	<b>BOARD</b>	<b>PURPOSE</b>
<p>RS-232C</p> 		<p>MPB</p>	<p>Serial Port</p>
<p>Serial to Audio Jack</p> 		<p>VOIB8, VOIB24, VMIB, AAIB PRIB, BRIB2, BRIB4, WTIB4, WTIB8</p>	<p>Serial Port</p>
<p>Audio Jack</p> 		<p>MPB</p>	<p>EXT MOH Port EXT PAGE Port</p>

---

## 3.3 Installation and Safety Precautions

---

Please read the following guidelines concerning installation and wiring before installing the iPECS-MG System. Also, be sure to comply with applicable local regulations.

When installing the telephone wiring, basic safety precautions should always be followed to reduce the risk of fire, electric shock, and personal injury, including the following:

- Never install the telephone wiring during a lightning storm.
- Never install the telephone jack in wet locations unless the jack is specifically designed for wet locations.
- Never touch un-insulated telephone wires or terminals unless the telephone line has been disconnected at the network interface.
- Use caution when installing or modifying telephone lines.
- Anti-static precautions should be taken during installation.

The iPECS-MG System is designed for wall mounting or a freestanding rack. Avoid installing in the following places:

- In direct sunlight and extremely hot, cold, or humid places (optimal temperature range = 0o to 40oC).
- Places where shocks or vibrations are frequent or strong.
- Dusty places or places where the System may encounter water or oil.
- Near high frequency generating devices such as sewing machines or electric welding machines.
- On or near computers, fax machines, or other office equipment, as well as microwave ovens or air conditioners.
- Do not obstruct the openings on the sides of the iPECS-MG System.
- Do not stack up the Optional Service Boards.

Be sure to follow these precautions when wiring:

- Do not wire the telephone cable in parallel with an AC power source, computer, fax machine, etc. If the cables are run near such wires, shield the cables with metal tubing or use shielded cables and ground the shields.
- If the cables are run on the floor, use protectors to prevent the wires from being damaged by foot traffic. Avoid wiring under carpets.
- Do not use the same power supply outlet for computers, fax machine, and other office equipment to avoid inducing RF noise into the iPECS-MG system.
- The power and battery switches must be OFF during wiring. After wiring is completed, the power switch may be turned ON.
- If an extension does not operate properly, disconnect the telephone from the extension line and then re-connect, or turn the System power OFF and then ON again.
- Use unshielded twisted pair cable for connecting CO lines and stations.

## 4. K<sub>SU</sub> INSTALLATION

### 4.1 B<sub>KSU</sub> Unpacking

Open the box and verify the items shown in Figure 4.1-1 B<sub>KSU</sub> Carton Contents are included:

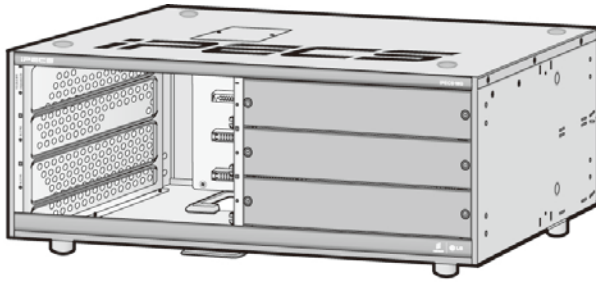

Key Service Unit



Rack Mounting Bracket



Screw



Tie Cable



CD manual



Power Cord



Backup Battery Cable

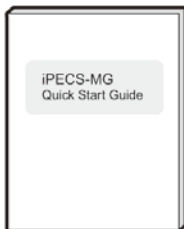

Quick Start Guide

Figure 4.1-1 B<sub>KSU</sub> Carton Contents

## 4.2 EKSU Unpacking

Open the box and verify the items shown in Figure 4.2-1 EKSU Carton Contents are included:

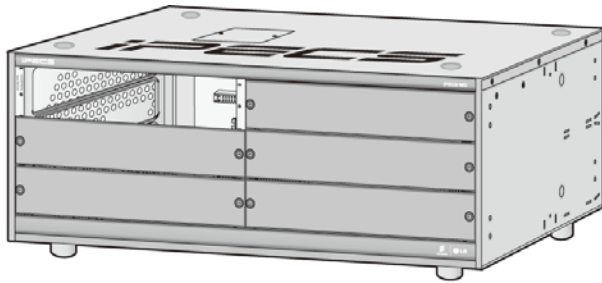

### Key Service Unit

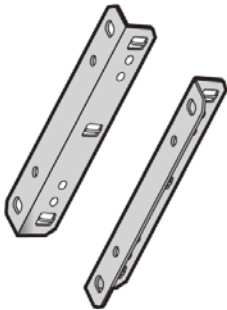

Rack Mounting Bracket



Screw



Tie Cable

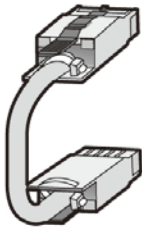

Expansion Cable



Power Cord



Backup Battery Cable

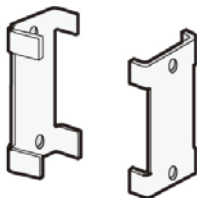

Fastener



Screw

Figure 4.2-1 EKSU Carton Contents

### 4.3 KSU Diagram, Exterior and Dimension

For reference purposes, Figure 4.3-1 shows the exterior and dimensions of the KSU.

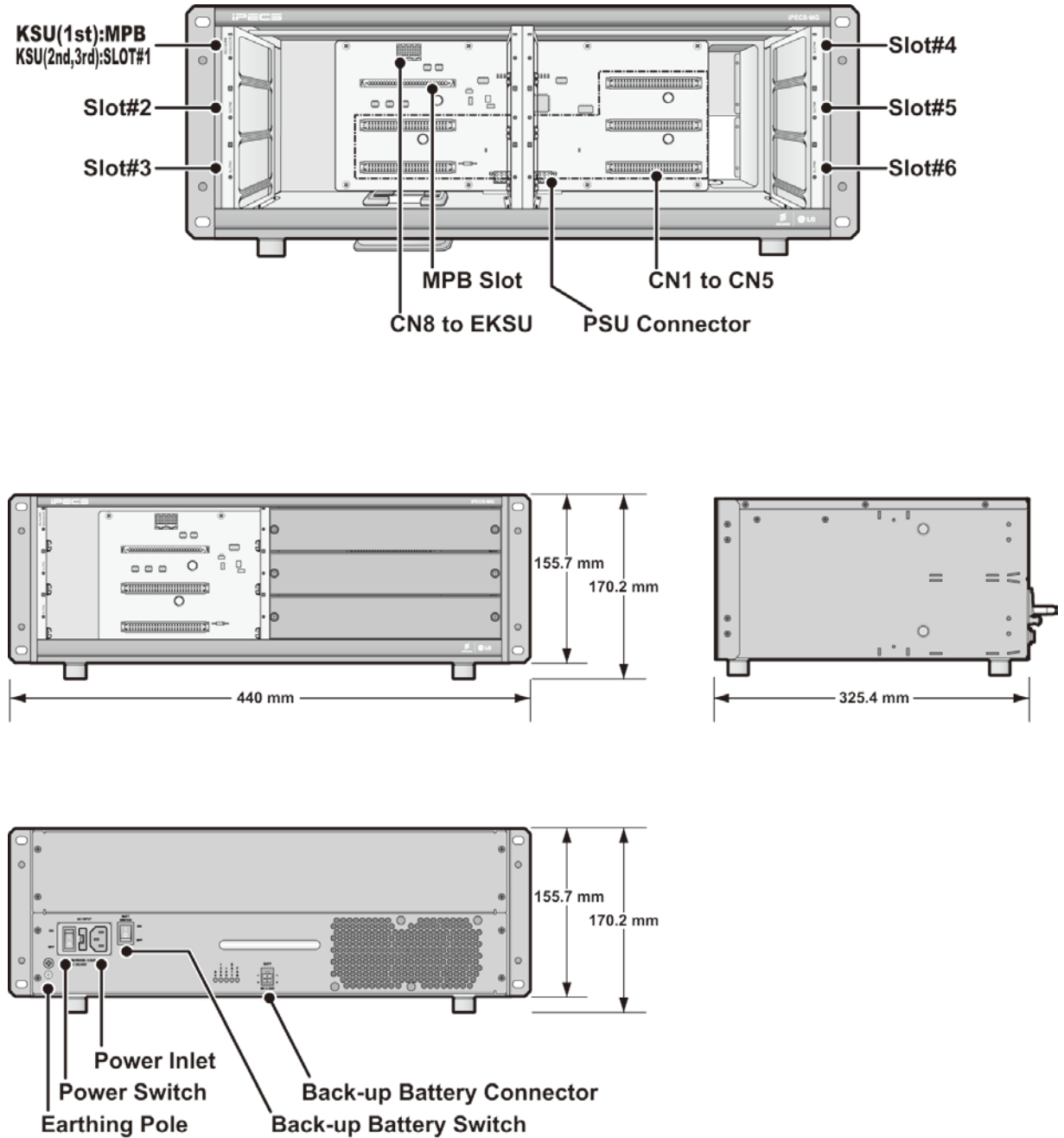

Figure 4.3-1 KSU Exterior and Dimension

## 4.4 Basic KSU Mounting

The KSU can be 19" rack or wall mounted.

### 4.4.1 Rack Mounting

1. Install the Rack Mount brackets to each side of the KSU with the eight (8) screws provided.
2. Insert screws with washers through the Rack Mount bracket flange on each side of the cabinet.
3. As required, thread screws into nuts, or directly into threaded holes in the rack
4. Tighten the screws securely to complete the rack mounting. These screws are supplied with the rack.

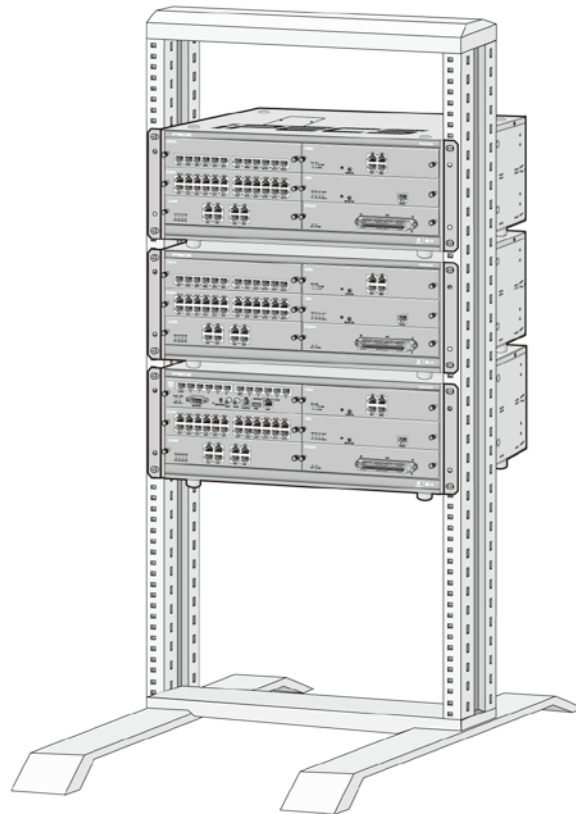
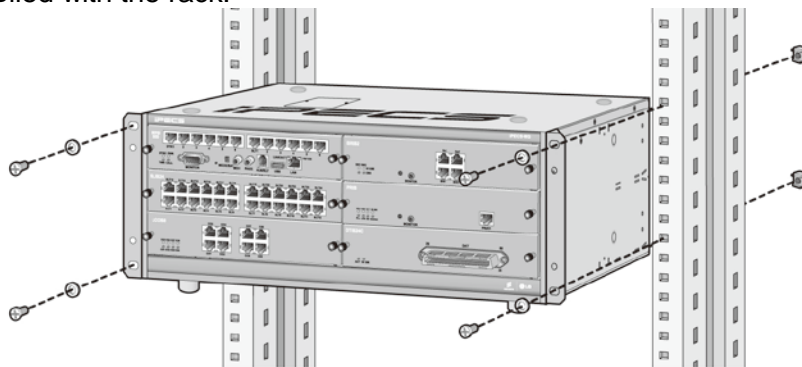

Figure 4.4.1-1 Rack Mounting

## 4.4.2 Wall Mounting

1. Attach the included mounting template for accurate placement to the wall, level, and drill 12 holes.
2. Install 12 anchor plugs into the wall using the mounting template (Figure 4.4.2 1 Wall Mounting).
3. Insert 12 included screws into the 12 anchor plugs.
4. Tighten the screws leaving about 5 mm (0.2 inches) exposed
5. Hook the Wall Bracket onto installed screws and tighten screws.
6. Install the Rack Mount brackets to each side of the KSU with the eight (8) screws provided.
7. Attach the Wall Shelf brackets to the bottom of KSU and affix using the eight (8) screws provided.
8. Hook the Wall Shelf brackets onto the Wall Bracket, making sure that the System slides down securely.
9. Affix the Wall Shelf brackets to the Wall Bracket using the four (4) screws provided.

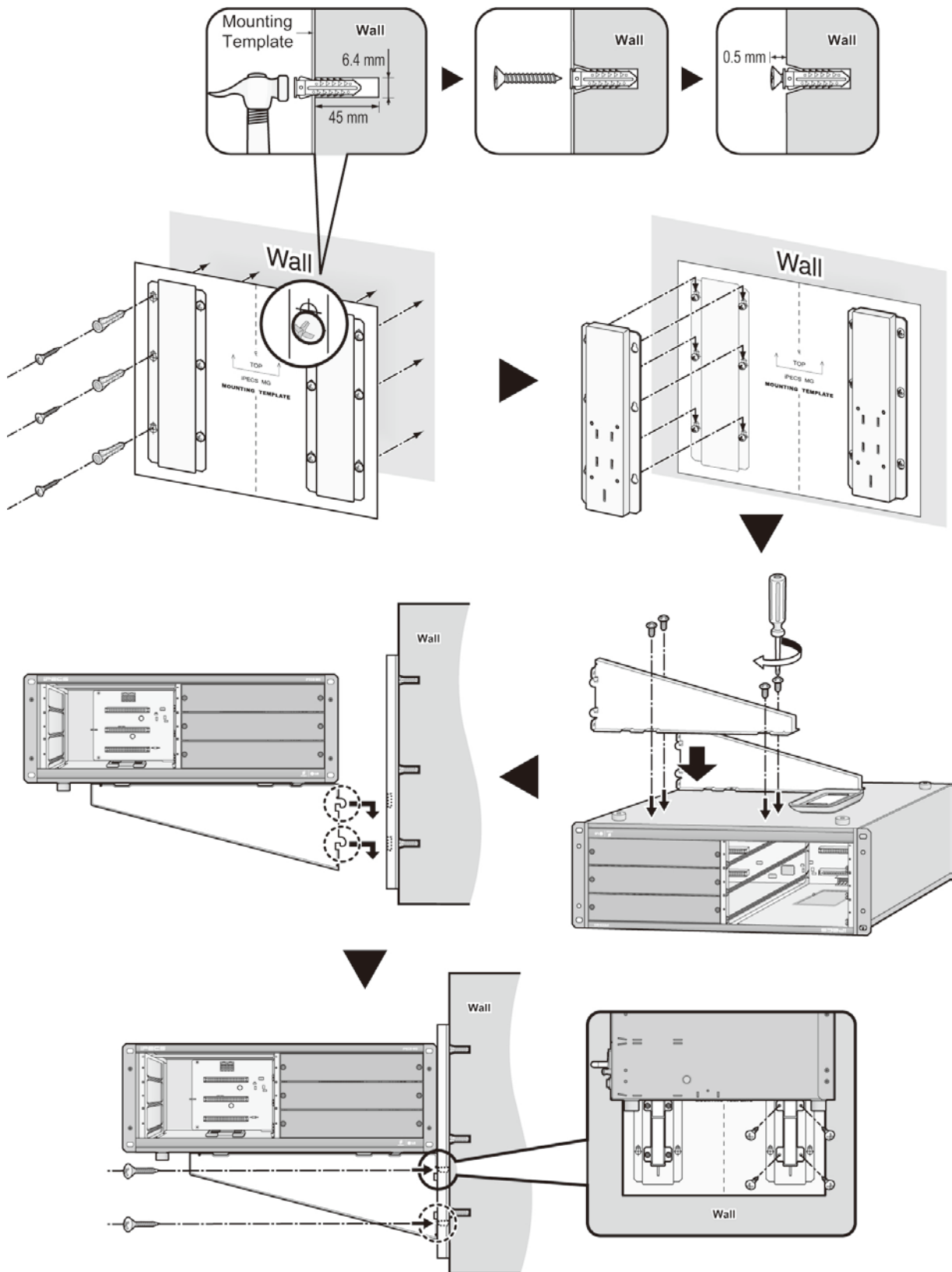

Figure 4.4.2-1 Wall Mounting



---

## 4.5 Expansion KSU Installation

---

The Expansion KSU is installed on top of the Basic KSU. Fasteners are installed on each side of the KSUs to maintain a stable mechanical connection. The Expansion cable is installed to connect the KSU backplane signaling and media (voice) paths. Use the following instructions and Figure below to install.

1. Remove the Expansion Cable Cover Plates on the top of the BKSU and bottom of the EKSU. Remove the two screws holding the Cover plate and remove the Cover plate.
2. Install the Rack Mounting brackets on the EKSU with the screws provided.
3. For Wall Mounting  
Place the EKSU on top of the BKSU, making sure to align the feet of the EKSU with the cavities in the lower KSU.  
For 19" Rack mounting,  
Insert screws and washers through the Rack Mounting bracket on each side of the cabinet.  
If required, thread screws into nuts, or directly into threaded holes in the 19" rack and tighten screws securely.
4. Install the Fasteners on each side of the cabinets using the screws provided with the EKSU.
5. Install the Expansion cable between the two cabinets. Attach one connector to the C8 mating connector in the lower KSU and the other end to C9 in the upper KSU. It may be necessary to remove the blank Slot cover plates from the front of the KSUs.



### CAUTION

- Be careful not to bend the pins of Expansion Cable connectors.

If the site requires a second EKSU, install and connect the second EKSU to the first EKSU as described above.

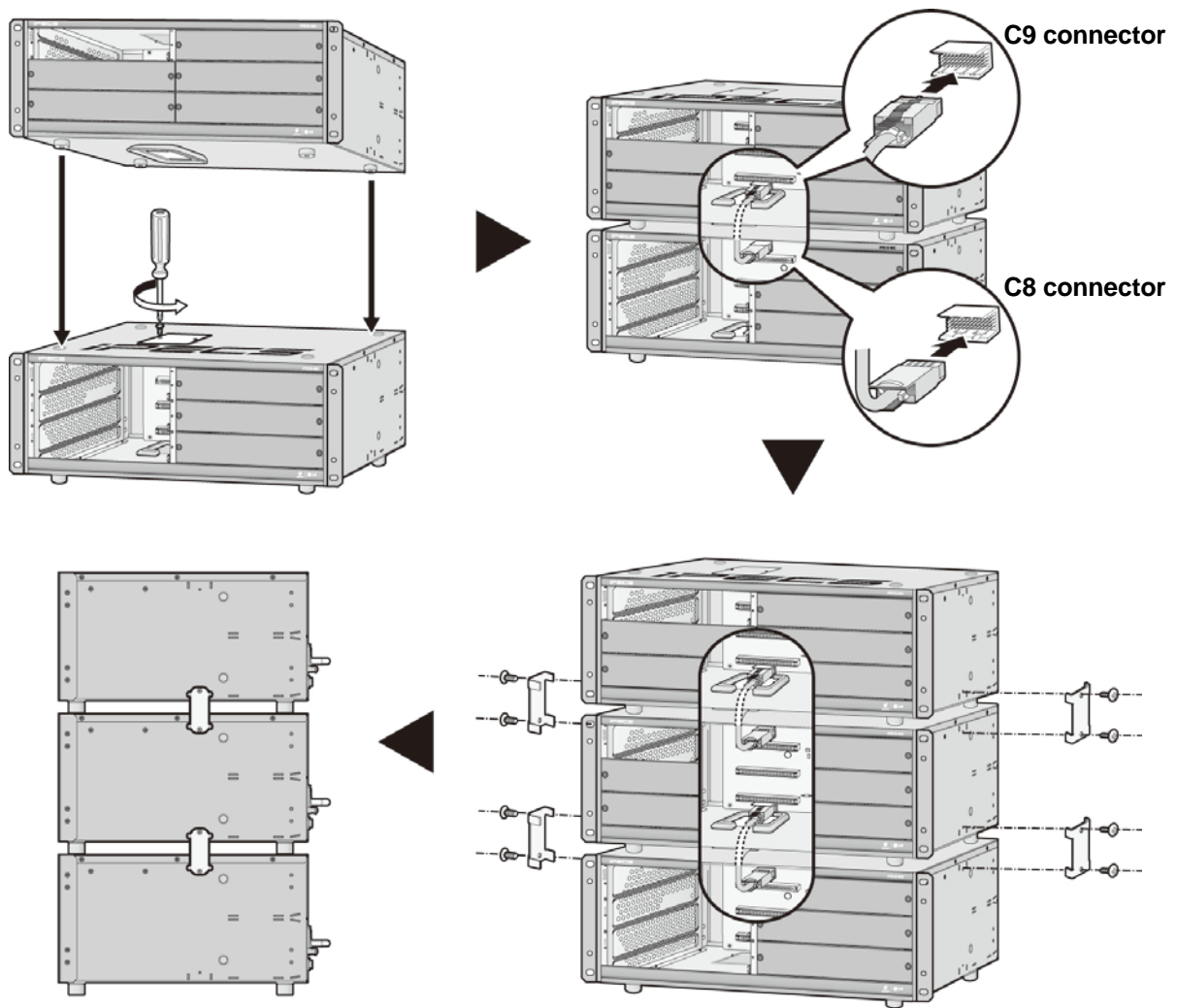

Figure 4.5-1 Expansion KSU installation

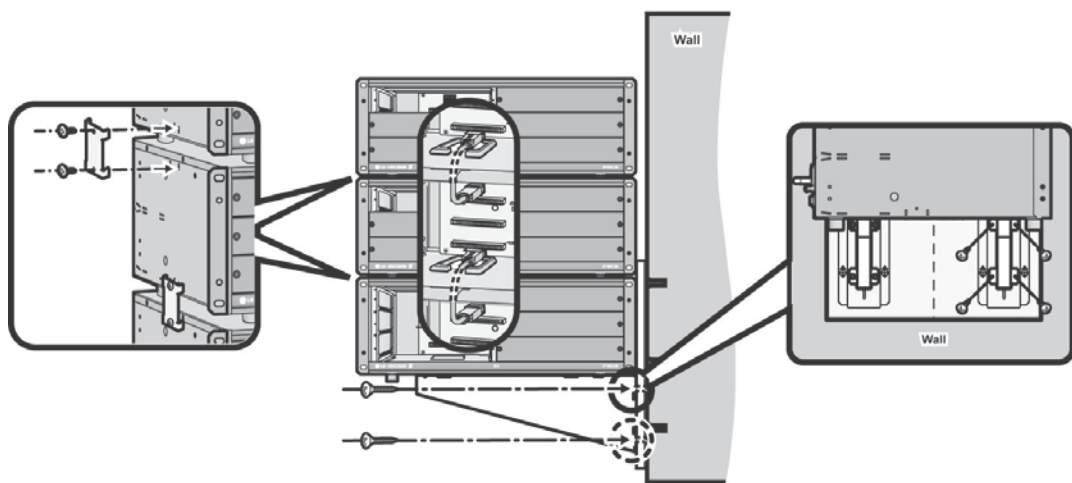

Figure4.5-2 Expansion KSU Wall Mounting

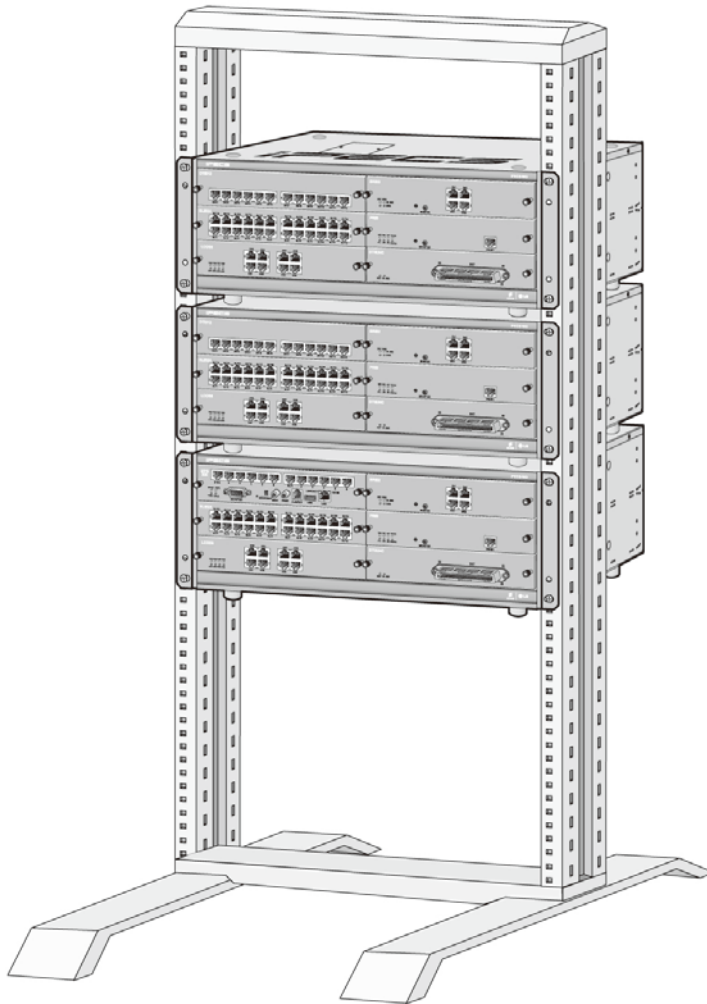
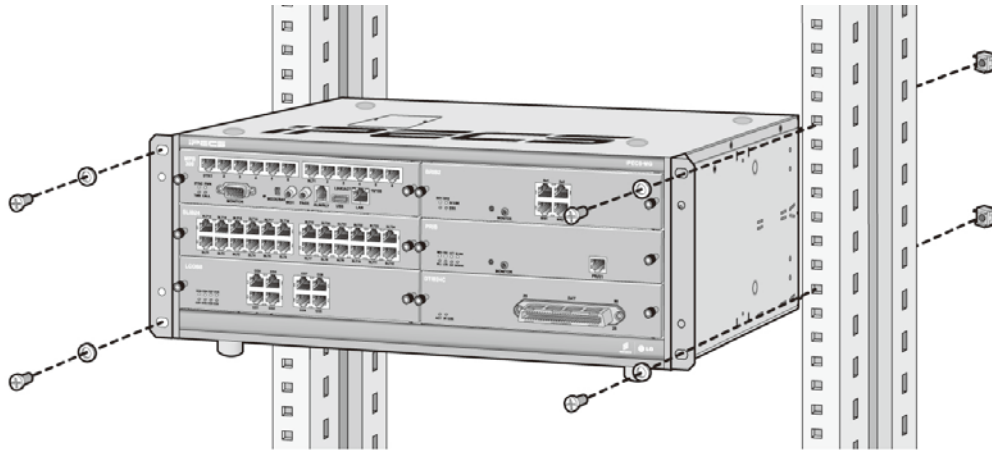

Figure 4.5-3 Expansion KSU Rack Mounting

## 4.6 Power Supply Unit Wiring

Each KSU is equipped with a Power Supply Unit (PSU) that converts AC power to the DC voltages required by the system. The DC voltages are distributed to the various boards in the cabinet by the backplane wiring under control of the MPB. For PSU specifications see section 2.4.3.

The PSU in each cabinet should be connected to a common Earth or Frame ground and, if Battery Back-up operation is required, each PSU should be connected to a Battery Back-up circuit. Each PSU also requires a separate connection to AC power.

### NOTE

#### Proper Power-up and down sequence

Turn off the PSU in the EKSU(s) then turn off the PSU in the BKSU. If the PSU in the BKSU is turned off first, the system will automatically remove power from the EKSU.

The 1st and 2nd KSUs will work independent of the 3rd KSU (power shut-Off).

The 1st KSU will work independent of the 2nd KSU (powered-Off); however, the 3rd KSU cannot work without the 2nd KSU powered-On.

It is recommended that the iPECS-MG be reset if the PSU in an EKSU is power cycled or turned OFF.

### 4.6.1 Frame Ground Connection

Proper grounding minimizes the affect of power induced and RF noise, and reduces the risk of damage or injury in case of a power cross or lightning strike. Be sure to comply with applicable local regulations regarding grounding of equipment. To ground the system, at each KSU,

1. Assure the system is not connected to AC power.
2. Loosen the Ground lug screw by turning the screw counter-clockwise to loosen, as shown in Figure 4.6.1-1.
3. Strip approximately 15mm (1/2 inch) of insulation from the end of the ground wire. A UL1015 AWG #18 (1.0mm) green/yellow insulated copper wire should be used with a recommended length of 1 meter (3.28 feet) or less.
4. Insert the grounding wire in the ground lug and tighten the screw.
5. Then connect the grounding wire to an appropriate ground source. A cold water pipe with no insulated joints is often an acceptable ground.

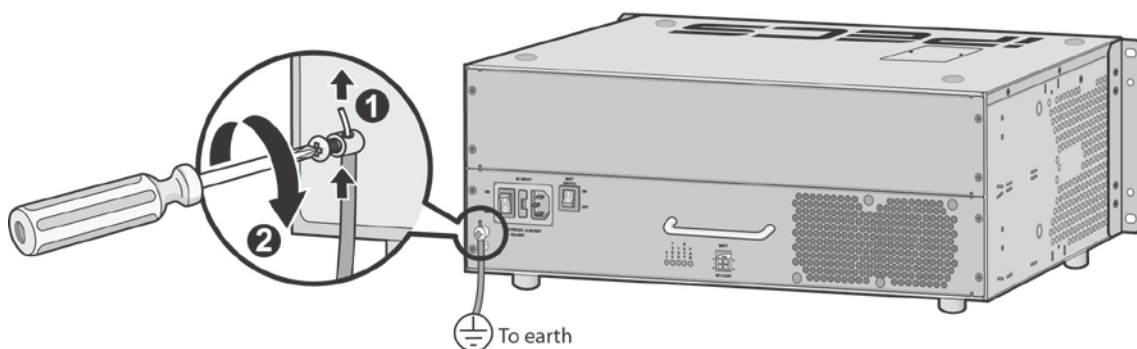

Figure 4.6.1-1 Grounding the KSU

## 4.6.2 External Backup Battery Installation

In case of power failure, the external backup batteries automatically maintain uninterrupted power for the iPECS-MG System. The external batteries must provide 24V DC; this is generally accomplished by connecting two 12V batteries in a series arrangement as shown:

- connect the backup battery cable with 2 identical batteries. (12V DC)
- insert a fuse between the batteries as shown.
- connect the external back up battery cable to the battery connector of the PSU.
- after connecting the external backup battery cable, turn on the battery switch.

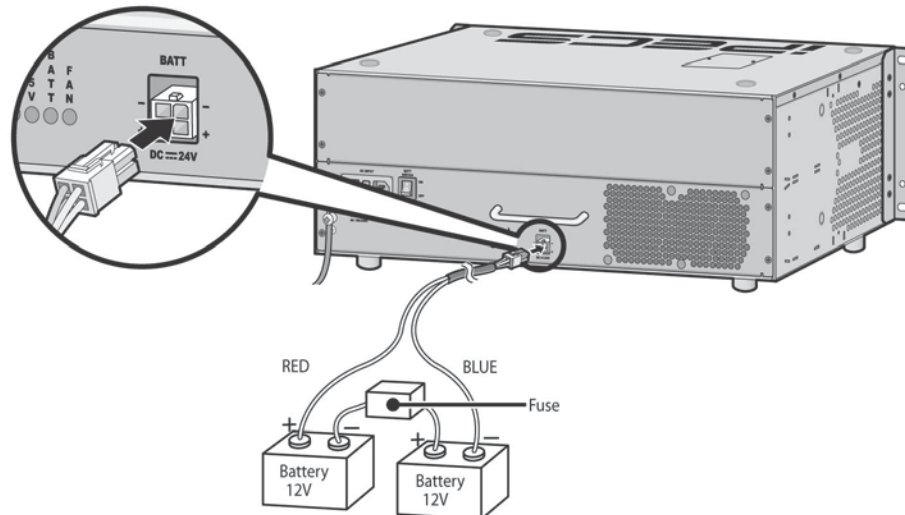

Figure 4.6.2-1 External Backup Battery Installation

### NOTE

#### the cable used to connect the battery is supplied with the KSU

- Battery operation is controlled by the PSU. The PSU will provide charging current to the batteries during normal AC power operation at a maximum of about 1 Amp. PSU battery operation will be halted if the AC power is re-connected or if the battery voltage is too low to maintain full-system operation.
- The length of time that the System will operate on the batteries is dependent on several elements including, battery charge, condition of the batteries, capacity of the batteries, and the size of the system (number of station ports). The chart below gives the approximate back-up times for several system sizes and different battery capacities in ampere-hours.

Table 4.6.2-1 Battery Capacities

BATTERY CAPACITY	DKT 24PORTS	DKT 72 PORTS	DKT 120 PORTS
20AH	6 hours	3 hours	1.5 hours
40AH	12 hours	6 hours	3 hours



**CAUTION**

- It is recommended to use an external backup battery fuse between the battery and the System.
- The battery must supply 24 VDC with a recommended capacity of 20 Amp-hours.
- Carefully check the battery polarity with cable colors (Red and Blue) when connecting the battery to the System.
- Do not short out the external batteries and cables.
- There is a danger of explosion if external batteries are incorrectly replaced. Replace only with the same or equivalent type recommended by the manufacturer. Dispose of used batteries according to the manufacturer's instructions.

### 4.6.3 Power Supply Unit Replacement

The PSU, which is located at the rear of the KSU, converts AC power to the DC sources required by the system. The PSU includes a replaceable fuse, 6.3 A @ 250V and cooling fans. Each KSU comes equipped with a PSU that is field replaceable.

**Table 4.6.3-1 PSU Capacity**

PSU TYPE	+5V DC	+27V DC	+30V DC
PSU (SMPS)	10.0A	1A (Battery charge)	10A

To remove the existing PSU

- Remove four (4) screws that hold the PSU to the KSU by turning the screws counter-clockwise.
- Using the PSU handle pull the PSU from the KSU.

To install the new PSU

- Insert the PSU along the guide rails on the rear side of iPECS-MG.
- Slide PSU into the KSU to firmly seat the PSU in the backplane connector
- To affix securely, insert and tighten four (4) screws as shown below.

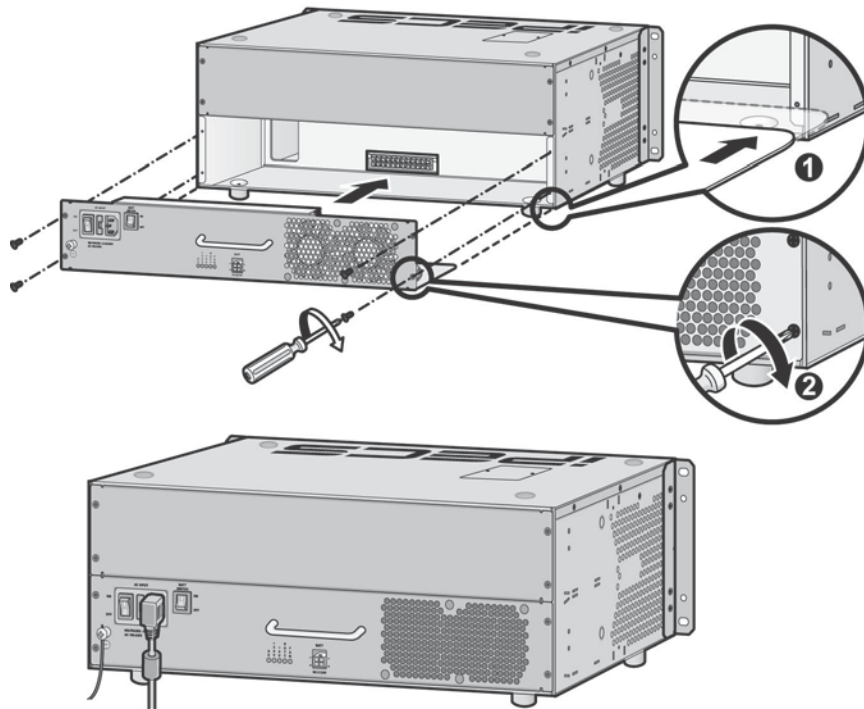

**Figure 4.6.3-1 PSU Installation**

**NOTE**

Turn OFF the PSU in the EKSU(s) then turn OFF the PSU in the BKSU. If the PSU in the BKSU is turned OFF first, the system will automatically remove power from the EKSU.

The 1st and 2nd KSUs will work independent of the 3rd KSU (power shut OFF).

The 1st KSU will work independent of the 2nd KSU (powered OFF); however, the 3rd KSU cannot work without the 2nd KSU powered-ON.

It is recommended that the iPECS-MG be reset if the PSU to an EKSU is power cycled or turned OFF.

## 5. BOARD INSTALLATION

### 5.1 General Board Install Procedure

Prior to installing the Boards, the following should be considered:

**! CAUTION**

- Verify the electrical Power is turned OFF before installation of boards.
- To protect the System from static electricity, do not directly touch the boards to discharge static, touch a grounded object, or wear a grounding strap.

To install the Board,

1. If required, install any option modules on the board and set any switches.
2. Slide the board along the guide rails into the KSU until the Board is securely seated in the backplane connector.
3. Press the thumbscrews in, and turn clockwise to affix the Board securely.
4. Wire the Board connectors as required.

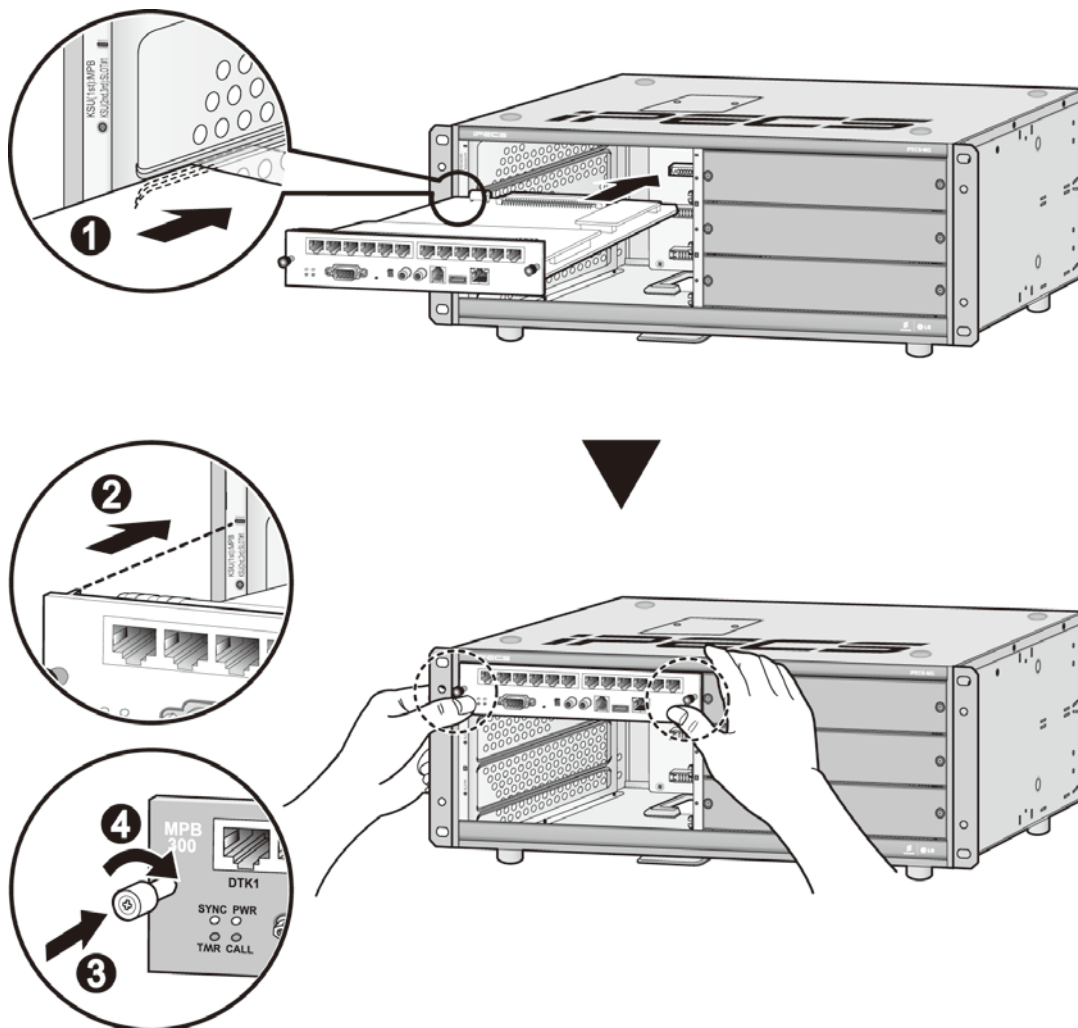

Figure 5.1-1 Board Installation



## 5.2 Main Processing Board

The Main Processor Board controls communication between the peripheral boards, supervises all resources in the system, controls the gain adjustment of the PCM signal, generates the System tones, maintains System audio prompts and manages System call processing. The MPB (Figure 5.2 1) is the main control for the System, and is composed of the microprocessor and memory, the PCM management and miscellaneous functional circuits.

The MPB must be installed in the MPB slot, the upper left (1st) slot of the BKSU.

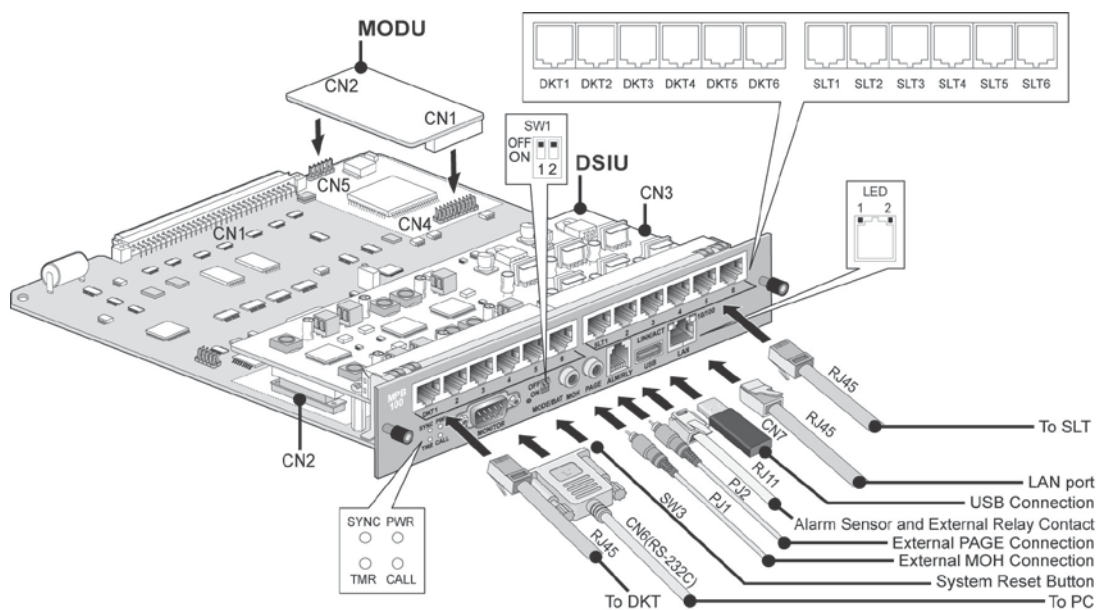

Figure 5.2-1 MPB

If an MPB is not installed, DC Power (+5V, +30V) will not feed to the backplane and other boards or EKSUs.

The following devices and functions are included on the MPB:

- Main Processor: MINDSPEED ARM9 Dual Core, M82805G, 375MHz
- PCM Voice Processing circuit (ACT2) - PCM voice switching, System Tone/Gain Control
- Tone (DTMF/CPT) Detection/CID Signal (FSK/DTMF/RCID) Detection/CID Generation
- Real Time Clock for System Time/Date
- System Memory [SDRAM/SRAM/Flash ROM/NAND Flash]
- PLL Circuit for ISDN Line Clock Synchronization
- 1 Internal MOH - 13 Music resources
- System Prompt storage, 3 languages
- Basic 4 AA Function (default) or 4 VoIP channel
- MODU (Option) Interface
- Basic DSIU Included 6 DKTs and 6 SLTs

- 4 Status Indication LEDs
- 1 RS-232C serial port
- 1 Reset Button
- 1 Switch for Admin Database back up
- 1 External MOH port
- 1 External Paging port
- 1 Alarm Detection port
- 1 Relay Contact for general purpose
- 1 USB port for DB upload and download, SW upgrade with Memory stick
- 1 Ethernet port – System maintenance, SW upgrade, and basic 4 channel VoIP

**Table 5.2-1 MPB 100 and MPB 300**

ITEM	MPB100	MPB300	REMARK
SRAM	2ea (4MB)	4ea (8MB)	User Data back up
ACT2	32 DSP channels	64 DSP channels	DTMF, CPT, CID Detection channels
MAX Ports	200	414	Available MAX (Trunk + Extension) Ports

**NOTE**

Except MAX Ports, RAM, and DSP channels, all functions of both MPB100 and MPB300 are the same.

## 5.2.1 Switch and LED Functions

The MPB has various switches and LEDs (refer to the following table).

**Table 5.2.1-1 Connector Jack and Switch Functions**

SWITCH & CONNECTOR	FUNCTIONS	DESIGNATION
SW1-1	Database Protect	MODE
SW1-2	Memory Battery	BAT
SW2	System Reset	
PJ1 (Red)	External MOH Connection	MOH
PJ2 (Blue)	External PAGE Connection	PAGE
MJ3 (RJ45)	Alarm Sensor and External Relay Contact	ALM/RLY
MJ2 (RJ45)	USB port	USB
MJ1 (RJ45)	LAN Port	LAN

After all the boards are installed and wiring complete and before programming the System, Switch 1-1 should be OFF and the system power turned ON to initialize the default System database. Once the database has been initialized, Switch 1-1 should be placed in the ON position to maintain the database and features programmed during Admin. Also, Switch 1-2 should be placed in the ON position, which connects the Lithium battery to protect the System database and real-time clock from a power loss.

**NOTE**

The battery has a 10+ year life and should not require replacement during the life of the System. If needed, replace the battery with the same or equivalent type recommended by the manufacturer. The System will not function normally if the battery is incorrectly replaced. Be sure to dispose of used batteries according to manufacturer instructions and/or local government regulations.

**Table 5.2.1-2 LED Indications**

LED	DESCRIPTION
LD1 (Blue), TMR	Timer, Periodic Toggle — ON, 100msec; OFF, 100msec.
LD2 (Blue), CALL	Call Task Status — ON, Call task activated; OFF, Call Task idle
LD3 (Blue), SYNC	External ISDN board (PRI or BRI) Clock synchronization ON: PLL circuit activation by External Clock from ISDN Board, iPECS-MG will be operated based on external ISDN clock (refer to "NOTE"). OFF: PLL activation by Internal Clock, iPECS-MG will be operated based on internal clock.
LD4 (Blue), PWR	System DC Power ON Indication – ON, Power ON; OFF, Power OFF

**NOTE**

When several PRIB/BRIBs are installed, the default clock priority will be as follows unless modified by the Admin (PGM301):

- Boards – PRIB > BRIB2 or BRIB4 > Internal Clock
- KSUs – 1'st KSU > 2'nd KSU > 3'rd KSU
- Slot – Slot 1 > Slot 2 >...> Slot 18

**Table 5.2.1-3 LAN Connector LED Indication**

LED	DESCRIPTION
1 (Green)	Link Status LED – ON: Link OK, OFF: No Link
2 (Orange)	Speed Status LED – ON: 100Mbps, OFF: 10Mbps

## 5.2.2 Modem Unit Installation

Before installing the MPB, if required, the optional Modem Unit (MODU) must be installed. The MODU is an analog modem supporting Bell, ITU-T, V.34, V.32BIS, V.90 Protocol at a baud rate of 300bps to 33Kbps with automatic rate negotiation. The MODU provides a modem for connection to the system database and maintenance functions. The MODU can be accessed remotely over an analog CO line by calling the Modem CO line or Station. For additional information on MODU set-up, see the iPECS-MG Admin Manual.

The MODU is installed on connectors CN4 and CN5 of the MPB as shown in Figure 5.2-1. Use care to align pins of the CN4 and CN5 connector with the CN1 and CN2 connectors on the MODU and press firmly in place.

## 5.2.3 MPB Installation

Before installing the MPB, mount the optional MODU as described above. The MPB must be installed in the MPB slot, the upper left slot of the BKSU.

- Assure Power is OFF
- Slide the MPB in the guide rails of the first slot (upper left) of the Basic KSU.
- Tighten thumbscrews to hold the board firmly in place.

## 5.2.4 LAN Port Wiring

The LAN connector accesses the System Ethernet port (10/100 Base-T) for Web access to the System database and maintenance functions as well as the basic 4 channel VoIP circuit, if installed. The LAN connector pin-outs are shown in the chart below and should be wired to an appropriate Ethernet switch port. Note that by reversing the TX and RX pins, the LAN connector can be directly connected to a PC for Admin and maintenance purposes.

**Table 5.2.4-1 LAN Port Connector**

CONNECTOR	PIN	SIGNAL	FUNCTION
RJ45 	4,5,7,8	Not used	
	1	TX+	Transmit Data
	2	TX-	Transmit Data
	3	RX-	Receive Data
	6	RX+	Receive Data

## 5.2.5 Connecting Miscellaneous Devices

The MPB provides connections for an external music source, an external page port, a relay contact, and an alarm detection input monitor.

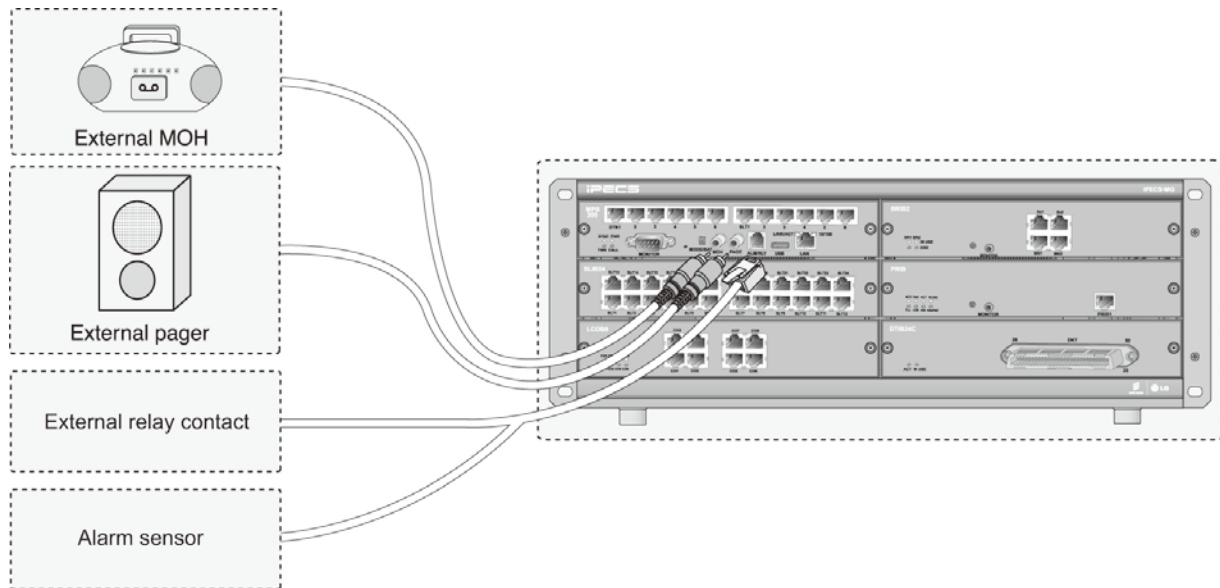

Figure 5.2.5-1 Miscellaneous Connections

### 5.2.5.1 Alarm/Relay Wiring

The RJ-11 Alm/Rly connector provides access to the Remote Contact Monitoring circuitry and an External Control Contact. The Contact Monitoring circuitry can be used to monitor an external alarm or doorbell contact. The External Control Contact activates as a Loud Bell, a Door Open control, or control for External paging equipment when External Paging is access.

Referring to Figure 5.2.5-1 and the pin-out chart below

- Wire the Alarm Tip and Alarm Ring located on pins 2 and 3 of the RJ11 to the Alarm contact termination point using UTP cable
- Wire the External Control Contact located at pins 4 and 5 of the RJ11 to the external device using UTP cable
- Tag or number wiring for maintenance

Table 5.2.5.1-1 Alarm and Relay Contact Connector

CONNECTION	PIN	SIGNAL NAME
RJ11 	1	Not used
	2	ALARM-T
	3	ALARM-R
	4	Relay-T
	5	Relay-R
	6	Not used

### 5.2.5.2 Page Audio Connector Wiring

The Page connector allows paging audio to be sent to External Paging equipment. The system will deliver audio as a 0-dBm signal into a 600-ohm load.

Referring to Figure 5.2.5-1,

- Wire the Page Audio connector to the termination point of the audio input of the External Page equipment.
- Tag or number wiring for maintenance.

### 5.2.5.3 MOH Connector Wiring

When a call is placed on hold, MOH (Music on Hold) is presented to the caller. MOH can be provided from an internal source or from an external audio source connected to the MOH connector.

Referring to Figure 5.2.5-1,

- Wire the MOH connector to the termination point of the audio output of the external MOH source.
- Tag or number wiring for maintenance.

### 5.2.6 USB Connector

The USB connector is provided to allow a USB memory stick to connect to the system for upload and download of the System database. No wiring of the USB connector is required. For further information on operation of the USB port, refer to the iPECS-MG Admin Manual.

**Table 5.2.6-1 USB Connector**

CONNECTOR	PIN	SIGNAL NAME
USB Type A 	1	GND
	2	D+
	3	D-
	4	VBUS (+5V)

### 5.2.7 RS-232 Monitor Wiring

The RS-232 female connector, which is a DCE (Data Communication Equipment), is used for various output functions (SMDR, Traffic Reports, etc.) and can be used to access the System database and maintenance functions through connection to a local PC.

**Table 5.2.7-1 RS-232 Monitor Connector**

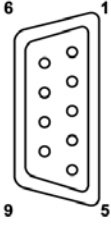
CONNECTOR	PIN	SIGNAL	FUNCTION
RS-232C 	1	Not used	
	2	TD	Transmitted Data
	3	RD	Received Data
	4	DSR	Data Set Ready
	5	SG	Signal Ground
	6	DTR	Data Terminal Ready
	7	CTS	Clear to Send
	8	RTS	Request to Send
	9	Not used	

**NOTE**

The RS-232C port on the MPB does not support hardware flow control.

Referring to the pin-out chart above and the wiring diagram below,

- wire the RS-232 port to an appropriate DTE (Data Terminal Equipment),
- tag or number wiring for maintenance

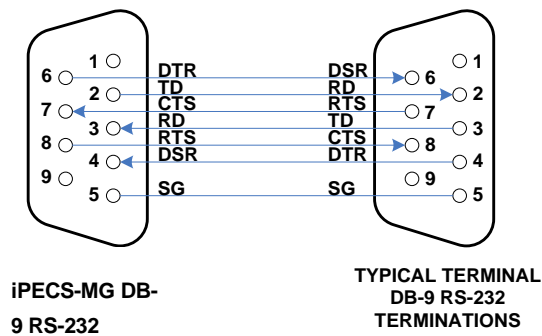

## 5.2.8 DSIU (Digital and Single Line Interface Unit) Wiring

The DSIU is included on the MPB and provides six (6) Digital Terminal (DKT-1 to 6) ports and six (6) Single Line (SLT 1 to 6) ports. The DSIU SLT ports support FSK (ITU-T V.23 or Bell 202) or DTMF (ITU-T Q.23) Caller ID to the SLT. The SLT ports provide the -48 VDC source, current limited to 20 mA, to operate the SLT, and support Message Wait Indication, DTMF or Pulse Dial, Polarity reversal, sinusoidal ring generator, and GR-909 Line Testing. The SLT and DKT ports of the DSIU are terminated in RJ45 connectors located in the front panel of the board. Note the DSIU is NOT field replaceable.

**Table 5.2.8-1 RJ45 Pin Assignment, DKT 1 to 6 Connectors**

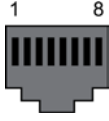
CONNECTOR	PIN	SIGNAL NAME
RJ45 	1,2,3	Not used
	4	DKT-T
	5	DKT-R
	6,7,8	Not used

**Table 5.2.8-2 RJ45 Pin Assignment, SLT 1 to 6 Connectors**

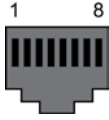
CONNECTOR	PIN	SIGNAL NAME
RJ45 	1,2,3	Not used
	4	SLT-T
	5	SLT-R
	6,7,8	Not used

Referring to the pin-out charts above,

- Wire the DKT and SLT ports of the DSIU to the termination point of the appropriate DKT or SLT. For information on terminal wiring, refer to section 6.
- Tag or number wiring for maintenance



## 5.3 CO Line Boards

### 5.3.1 LCOB (Loop Start CO Line Interface Board)

The iPECS-MG LCOB (Loop Start CO Interface Board) is employed to interface standard analog PSTN CO lines to the iPECS-MG system. The LCOB is available in three models, the LCOB4 with 4 analog CO ports, the LCOB8 with 8 ports, and the LCOB12 with 12 ports. The LCOB supports Caller Identification (CID) detection, Polarity Reversal (PR) detection and Call Progress Tone (CPT) detection. An optional CMU4 board, which supports four (4) LCOB ports each, is required to support call-metering service (50Hz, 12 kHz, and 16 kHz). In addition, the first port of the LCOB has a Power Failure Transfer (PFT) circuit that can be wired to an SLIB port for PFT service.

The below figure shows the LCOB8, which other than the added interface circuits is identical to the LCOB 4 and 12.

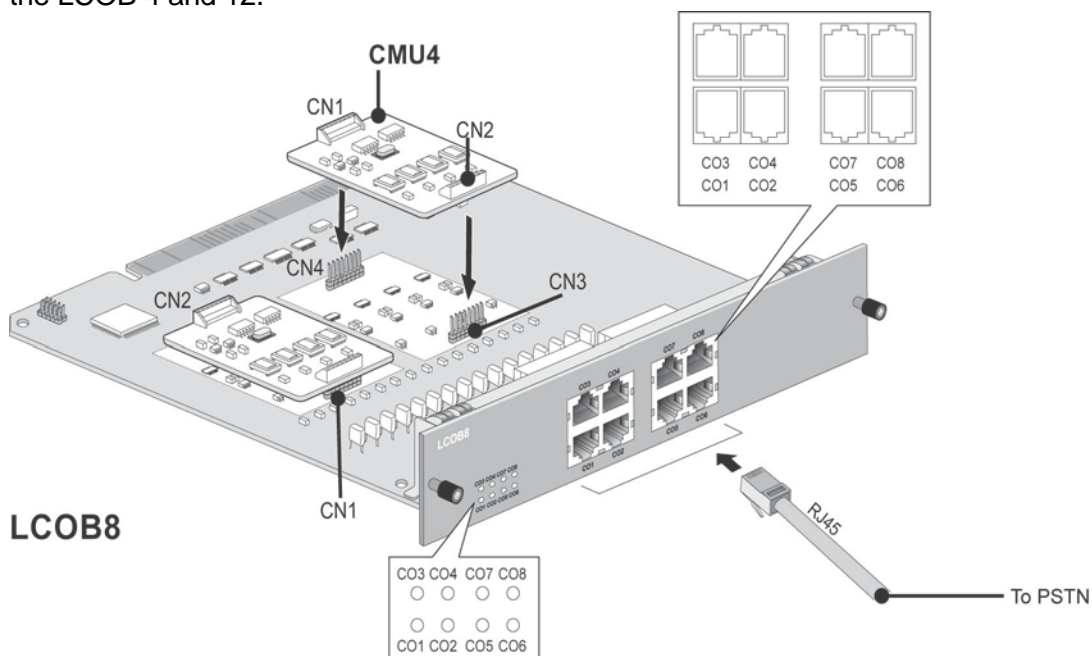

Figure 5.3.1-1 LCOB8

Table 5.3.1-1 Connector Functions

CONNECTOR	FUNCTION
CN1 and CN2	CMU4 connection for 1 <sup>st</sup> ~ 4 <sup>th</sup> ports
CN3 and CN4	CMU4 connection for 5 <sup>th</sup> ~ 8 <sup>th</sup> ports
CN5 and CN6	CMU4 connection for 9 <sup>th</sup> ~ 12 <sup>th</sup> ports

**Table 5.3.1-2 LED Indications**

LED	DESCRIPTION	LED	DESCRIPTION
LD1	1 <sup>st</sup> port - ON, In use ; OFF, Idle	LD7	7 <sup>th</sup> port - ON, In use ; OFF, Idle
LD2	2 <sup>nd</sup> port - ON, In use ; OFF, Idle	LD8	8 <sup>th</sup> port - ON, In use ; OFF, Idle
LD3	3 <sup>rd</sup> port - ON, In use ; OFF, Idle	LD9	9 <sup>th</sup> port - ON, In use ; OFF, Idle
LD4	4 <sup>th</sup> port - ON, In use ; OFF, Idle	LD10	10 <sup>th</sup> port - ON, In use ; OFF, Idle
LD5	5 <sup>th</sup> port - ON, In use ; OFF, Idle	LD11	11 <sup>th</sup> port - ON, In use ; OFF, Idle
LD6	6 <sup>th</sup> port - ON, In use ; OFF, Idle	LD12	12 <sup>th</sup> port - ON, In use ; OFF, Idle

### 5.3.1.1 CMU (Call Metering Unit) Installation

An optional CMU4 board, which supports four (4) LCOB ports each, is required to support call-metering service (50Hz, 12 kHz, and 16 kHz). For additional information on CMU, see the iPECS-MG Feature Manual.

Install a CMU4 on connector pairs CN1 and 2, CN3 and 4, and CN5 and 6 on the LCOB to support CO Line ports 1 and 12, as shown in Figure 5.3.1 1. Use care to align pins of the connector with the CN1 and CN2 connectors on the CMU and press firmly in place.

### 5.3.1.2 LCOB Installation

Before installation of the LCOB, make sure CMU4s are installed, if required. The LCOB board can be installed in any universal slot of any KSU; the 1st slot of the BKSU is for the MPB only.

- Assure Power is OFF
- Slide the LCOB in the guide rails of the desired slot.
- Tighten thumbscrews to hold the board firmly in place.

### 5.3.1.3 LCOB Wiring

The CO Line Tip and Ring terminations are located on the center pair of each RJ45 connector. A separate RJ45 is provided for each analog CO Line supported by the LCOB (4, 8, or 12).

Referring to the pin-out chart below,

- Wire the CO Tip and Ring pins to the PSTN CO Line termination point using UTP cable.
- Tag or number wiring for maintenance.

**Table 5.3.1.3-1 LCOB Ports**

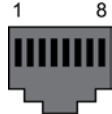
CONNECTOR	PIN	SIGNAL NAME
RJ45 	1,2,3	Not used
	4,5	CO-T, CO-R
	6,7,8	Not used

The first LCOB CO Line port supports PFT (Power Fail Transfer), when power is lost the CO Line is connected to an SLT port of an SLIB. To support PFT, referring to the pin-out chart below,

- wire pins 1 and 2 of the 1st LCOB port RJ45 to the appropriate SLIB port. For SLIB wiring, refer to section 5.4.1 and 5.4.2.
- tag or number wiring for maintenance

**Table 5.3.1.3-2 PFT Port 1<sup>st</sup> Port**

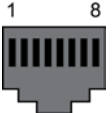
CONNECTOR	PIN	SIGNAL NAME
RJ45 	1,2	PFT-T, PFT-R
	3	Not used
	4,5	CO-T, CO-R
	6,7,8	Not used

### 5.3.2 BRIB (Basic Rate Interface Board) w/Selectable S/T Interface

There are two kinds of BRIB2/BRIB4 according to CPU, but they have the same functions.

The BRIB is available in two models, the BRIB2 with two (2) BRI lines (4 channels) and the BRIB4 with four (4) BRI lines (8 channels). The BRIB is compatible with ETSI 300.012 and ITU-T recommendations I.430 supporting S (Subscriber) or T (Trunk) interfaces. As shown in Figure 5.3.2.1, the S interface of the BRIB acts as the NT (Network Termination) connecting to TEs (Terminal Equipments) and can provide power feed (-40VDC) to the attached TEs (maximum eight TEs). A 100-ohm Terminating Resistor can be inserted across the TX and/or RX pair. When used, a 100-Ohm terminating resistor should be connected across the TX and RX pair at one of the TEs.

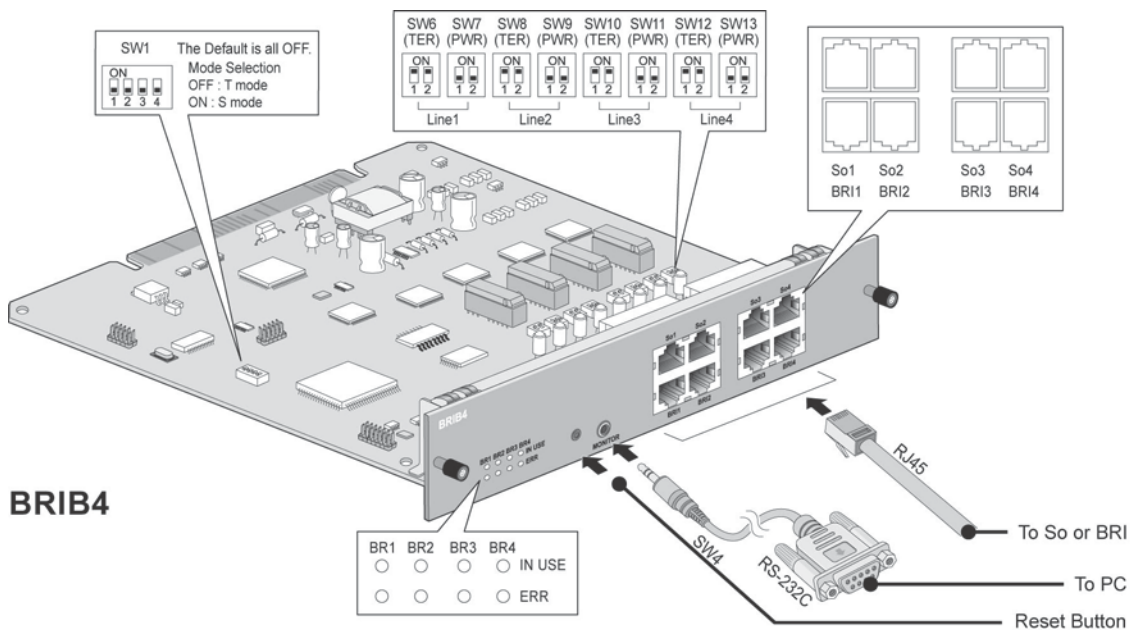
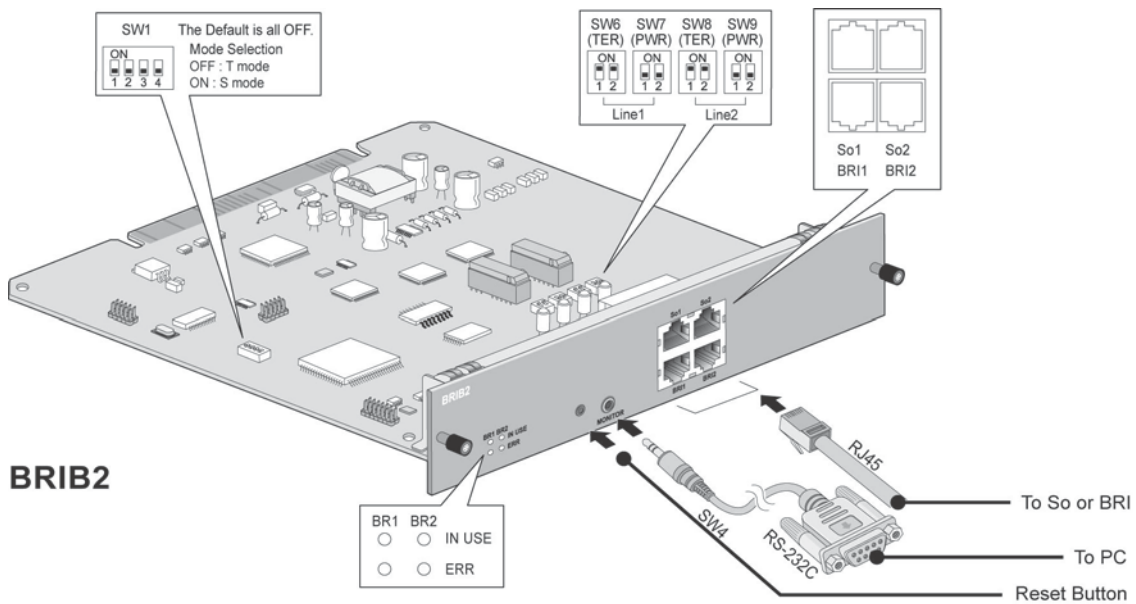

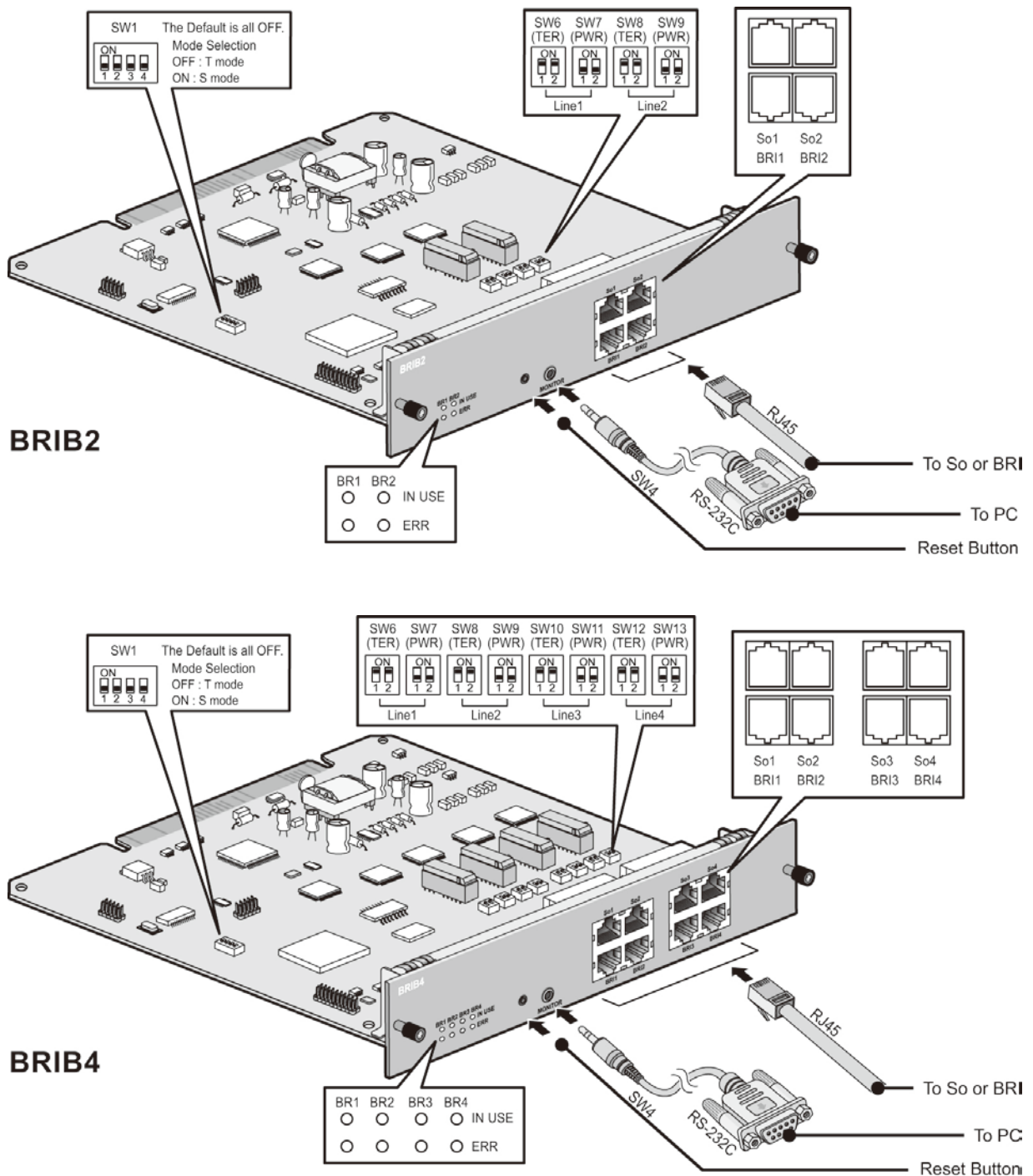

Figure 5.3.2-1 BRIB2 and BRIB4

**Note**

iPECS-MG does not support daisy chained clocking for digital lines. The clock priority and synchronization is controlled by Admin. For details, refer to PGM 301 of the iPECS-MG Admin Manual.

The default clock is assigned based on the board type, KSU, and slot as below.

- Board – PRIB > BRIB2/BRIB4 > Internal Clock
- KSU – 1’st KSU > 2’nd KSU > 3’rd KSU
- Slot – Slot 1 > Slot 2 >...> Slot 18

### 5.3.2.1 Switch and LED Functions

**Table 5.3.2.1-1 BRIB Line Mode Switch SW1**

SWITCH	FUNCTION	ON	OFF
SW1-1	Line #1 mode	S-mode	T-mode
SW1-2	Line #2 mode	S-mode	T-mode
SW1-3	Line #3 mode	S-mode	T-mode
SW1-4	Line #4 mode	S-mode	T-mode

**Note**

The default setting is T Mode for all switches. SW1-3 and SW1-4 are for BRIB4 only.

**Table 5.3.2.1-2 BRIB Terminating Resister (100-Ohm)**

SWITCH	FUNCTION	ON	OFF
SW6-1	Line 1 TX resistor	Terminate	Open
SW6-2	Line 1 RX resistor	Terminate	Open
SW8-1	Line 2 TX resistor	Terminate	Open
SW8-2	Line 2 RX resistor	Terminate	Open
SW10-1	Line 3 TX resistor	Terminate	Open
SW10- 2	Line 3 RX resistor	Terminate	Open
SW12-1	Line 4 TX resistor	Terminate	Open
SW12-2	Line 5 RX resistor	Terminate	Open

**Table 5.3.2.1-3 BRIB Power Feed**

SWITCH	FUNCTION	ON	OFF
SW7-1	Line 1 Power Feed (-40V)	Feed	Open
SW7-2	Line 1 Power Feed (Ground)	Feed	Open
SW9-1	Line 2 Power Feed (-40V)	Feed	Open
SW9-2	Line 2 Power Feed (Ground)	Feed	Open
SW11-1	Line 3 Power Feed (-40V)	Feed	Open
SW11-2	Line 3 Power Feed (Ground)	Feed	Open
SW13-1	Line 4 Power Feed (-40V)	Feed	Open
SW13-2	Line 4 Power Feed (Ground)	Feed	Open

**Table 5.3.2.1-4 LED Indication, BRIB2**

NO	FUNCTION	STATUS
LD1 LD3	Line 1 status	Red: ON = Error Blue: ON = In-use, OFF = Idle
LD2 LD4	Line 2 status	Red: ON = Error Blue: ON = In-use, OFF: = Idle

**Table 5.3.2.1-5 LED Indication, BRIB4**

NO	FUNCTION	STATUS
LD1 LD5	Line 1 status	Red: ON = Error Blue: ON = In-use, OFF = Idle
LD2 LD6	Line 2 status	Red: ON = Error Blue: ON = In-use, OFF = Idle
LD3 LD7	Line 3 status	Red: ON = Error Blue: ON = In-use, OFF = Idle
LD4 LD8	Line 4 status	Red: Error Blue: ON = In-use, OFF = Idle

### 5.3.2.2 BRIB Installation

Before installation of the BRIB, set the Mode, Terminating Resistor, and Power Feed Switches for each BRIB Line. Note that the BRIB cannot simultaneously support both the T and S mode, all ports on the BRIB must be set in the same mode, T or S.

The BRIB board can be installed in any universal slot of any KSU; the 1st slot of the BKSU is for the MPB only.

- Assure Power is OFF
- Slide the BRIB in the guide rails of the desired slot.
- Tighten thumbscrews to hold the board firmly in place.

### 5.3.2.3 BRIB Wiring

A separate RJ45 connector is provided for each BRI line supported by the BRIB. Referring to the pin-out chart and Figure 5.3.2.3 1 below,

- Wire the TX and RX pins of each RJ-45 connector to the BRI digital line termination point using UTP cable.
- Tag or number wiring for maintenance.

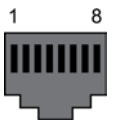

Table 5.3.2.3-1 RJ45

CONNECTOR	PIN	NAME (T-mode)	FUNCTION	NAME (S-mode)	FUNCTION
RJ45 	1,2,7,8	Reserved			
	3	TX+	Transmit Data	RX+	Receive Data
	4	RX+	Receive Data	TX+	Transmit Data
	5	RX-	Receive Data	TX-	Transmit Data
	6	TX-	Transmit Data	RX-	Receive Data

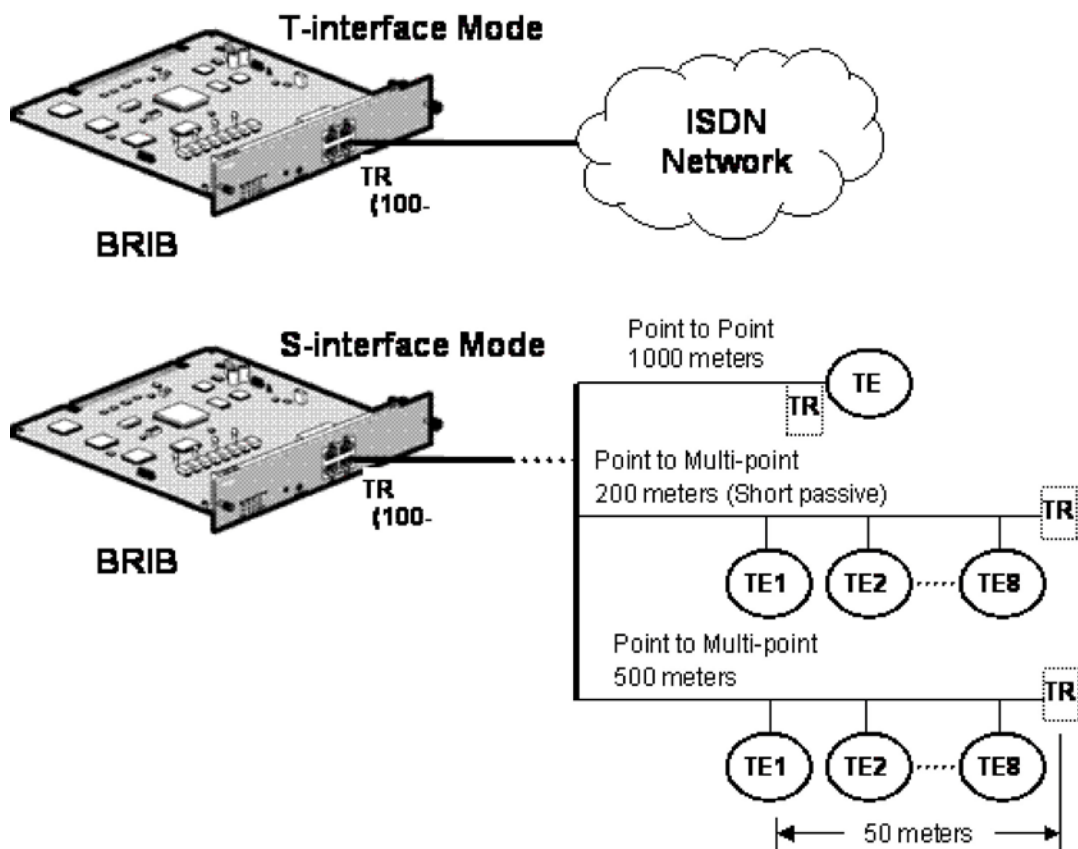

Figure 5.3.2.3-1 ISDN Connections (Basic Rate)

### 5.3.2.4 Serial Port

The PRIB includes an Audio jack connected to a Serial port. The serial port is used for diagnostic purposes. For wiring information, refer to section 5.6.

### 5.3.3 E1R2-PRIB (Primary Rate Interface Board)

There are two kinds of PRIB according to CPU, but they have the same functions.

The Primary Rate Interface Board (PRIB) provides one (1) PRI interface, or one (1) E1R2 interface. The PRI interface supports 30 PCM bearer and 2 signaling channels for PRI or E1R2. The PRIB is based on the interface described in ITU-T Recommendations G.704, G.703, and G.823. It covers CEPT frame format that consist of 32 8-bit timeslots, a data rate of 2.048MHz. From the 32 timeslots in a frame, 30 timeslots are defined as information channels, timeslots 1-15 and 17-31 that correspond to telephone channels 1-30. The frame has duration of 125µsec and contains 32 Time Slots (TS). Time Slot 0 is allocated to frame alignment sync, and Time Slot 16 is allocated to the signaling channel; the other time slots are available for allocation to the B channel. The CEPT frame has four signaling bits, A, B, C and D. Signaling bits for all 30 media channels are transmitted in timeslot 16. The PRIB supports pulse dialing, DTMF dialing, and MFC-R2 register signaling (based on ITU-T Recommendation Q.440-480).

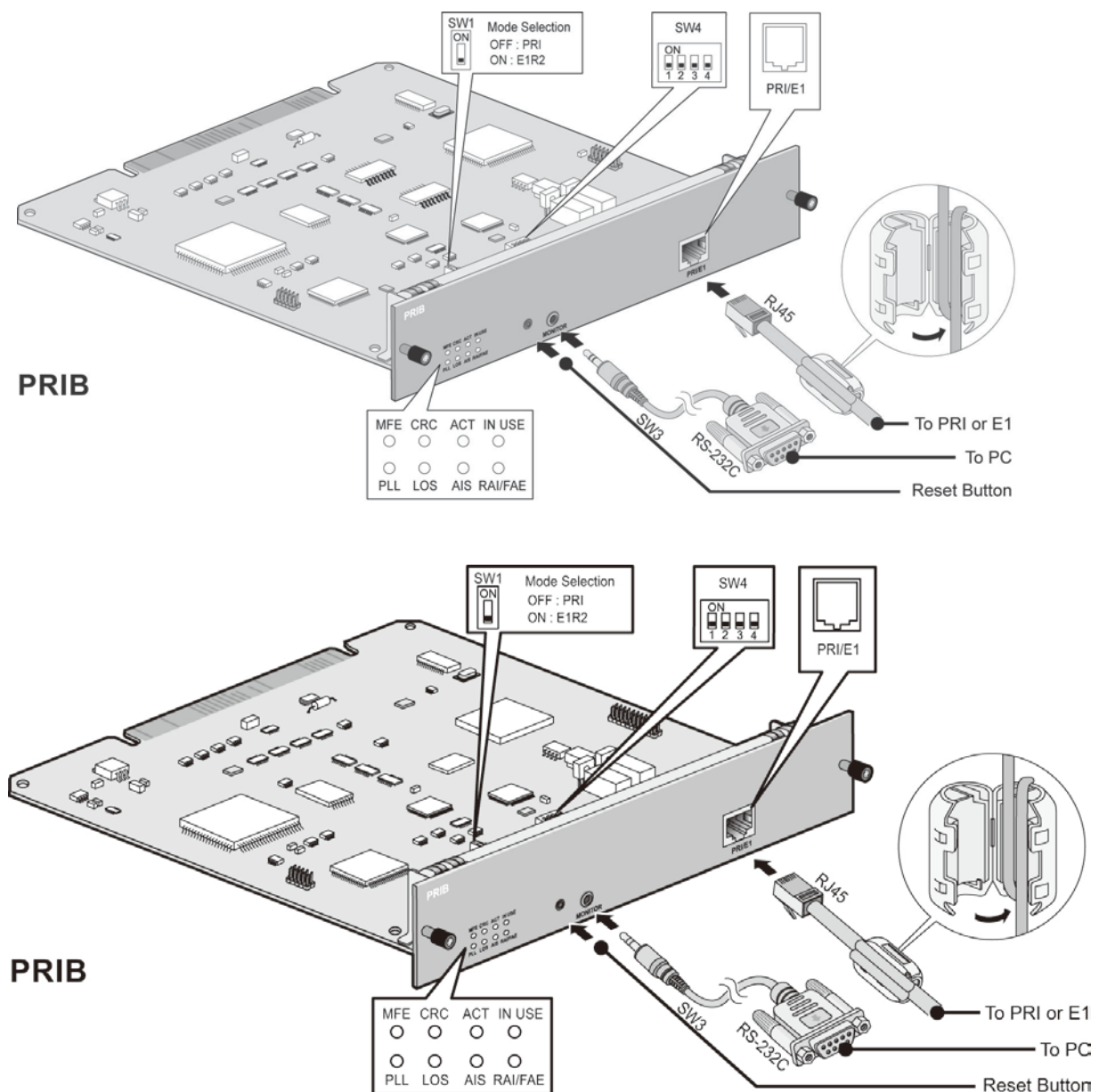

Figure 5.3.3-1 E1-PRIB



**CAUTION**

For QSIG operation, check the mode setting and the pin assignments of RJ45 type connector according to the mode of line, TE or NT.

**NOTE**

iPECS-MG does not support daisy chained clocking for digital lines. The clock priority and synchronization is controlled by Admin. For details, refer to PGM 301 of the iPECS-MG Admin Manual.

The default clock is assigned based on the board type, KSU, and slot as below.

- Board – PRIB > BRIB2/BRIB4 > Internal Clock
- KSU – 1’st KSU > 2’nd KSU > 3’rd KSU
- Slot – Slot 1 > Slot 2 >...> Slot 18

**5.3.3.1 Switch and LED Functions**

**Table 5.3.3.1-1 Switch-Functions**

SWITCH	FUNCTION	REMARK
SW1	Mode Selection (OFF = PRI, ON = E1R2)	Default: PRI mode
SW3	Reset switch	
SW4-1	Not used	
SW4-2	Not used	
SW4-3	Not used	
SW4-4	Not used	

**Table 5.3.3.2-2 LED-Indication**

LED	PRI MODE	E1R2 MODE	REMARK
LD1	PLL Synchronization		RED LED ON: Error OFF: Normal operation
LD2	Loss of Signal from the Line		
LD3	Alarm Indication Signal		
LD4	Remote Alarm Indication	Frame Alignment Error	
LD5	Multi Frame Error		
LD6	CRC Error	CRC (ON : Enable, OFF : Disable)	
LD7	Normal operation indication (Activity Indication)		Blue (Blink)
LD8	Channel status		Blue LED ON: Channels in use OFF: All channels Idle)

**5.3.3.2 E1-PRIB Installation**

Before inserting the PRIB, set SW1 and SW4 Dip switches to match the Telco provided service. The PRIB board can be installed in any universal slot of any KSU; the 1st slot of the BKSU is for the MPB only.

- Assure Power is OFF
- Slide the PRIB in the guide rails of the desired slot.
- Tighten thumbscrews to hold the board firmly in place.

### 5.3.3.3 E1-PRIB Wiring

The E1-PRIB Transmit and Receive pairs are terminated in the PRI/E1 RJ45 connector. A single RJ45 is provided for the digital line interface.

Before wiring the PRIB, the Ferrite core provided with the E1-PRIB must be installed to reduce EMI (Electro-Magnetic Interference). To install the Ferrite core,

- Open the core,
- Insert and loop the RJ45 terminated cable for the E1-PRIB through the core as shown in Figure 5.3.3-1.
- Close the Ferrite core over the cable.

Referring to the pin-out chart and Figure 5.3.3.3-1 E1-PRIB Connector Wiring Diagram below,

- Wire the TX and RX pins of the RJ45 connector to the digital line termination point using UTP cable.
- Tag or number wiring for maintenance.

**Table 5.3.3.3-1 PRI Port**

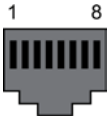
CONNECTOR	PIN	SIGNAL
RJ45 	1	RX+
	2	RX-
	4	TX+
	5	TX-
	3,6,7,8	Not used

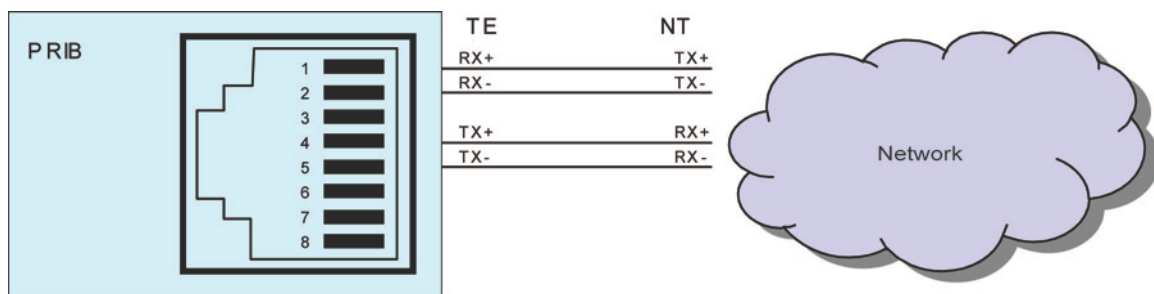

**Figure 5.3.3.3-1 E1-PRIB Connector Wiring Diagram**

### 5.3.3.4 Serial Port

The PRIB includes an Audio jack connected to a Serial port. The serial port is used for diagnostic purposes. For wiring information, refer to section 5.6.

### 5.3.4 T1-PRIB (Primary Rate Interface Board)

There are two kinds of PRIB according to CPU, but they have the same functions.

The T1 and Primary Rate Interface (PRI) board interfaces to North American standards based digital networks. Standard alarms are provided by on-board LEDs (refer to chart below). The PRIB includes the T1-PRI interface, control and synchronous clock circuitry as well as standard alarm indications using front panel LEDs (refer to LED Indications chart below).

The board is switch-selectable (SW1) for T1 or PRI operation both operating with a 125 usec frame at 1.544Mb/s. In T1 operation, the standards EIA/TIA-464-A and TR 41458 24-channel interface supporting DID, TIE Line, and Loop or Ground Start are implemented. The DID and TIE Line operation support Immediate, Delayed and Wink start signaling protocols. The Telco interface must provide BZ8S line coding and Extended Super Frame (ESF) framing.

In PRI operation, the ISDN standard NII2 (National ISDN Interface 2) 23 Bearer and one (1) Data channel interface is supported. The PRI operation employs ANSI T1.403, T1.601, T1.605, and TR62411 standards.

Connection is made via a RJ45 from the PRIB to a CSU (Channel Service Unit).

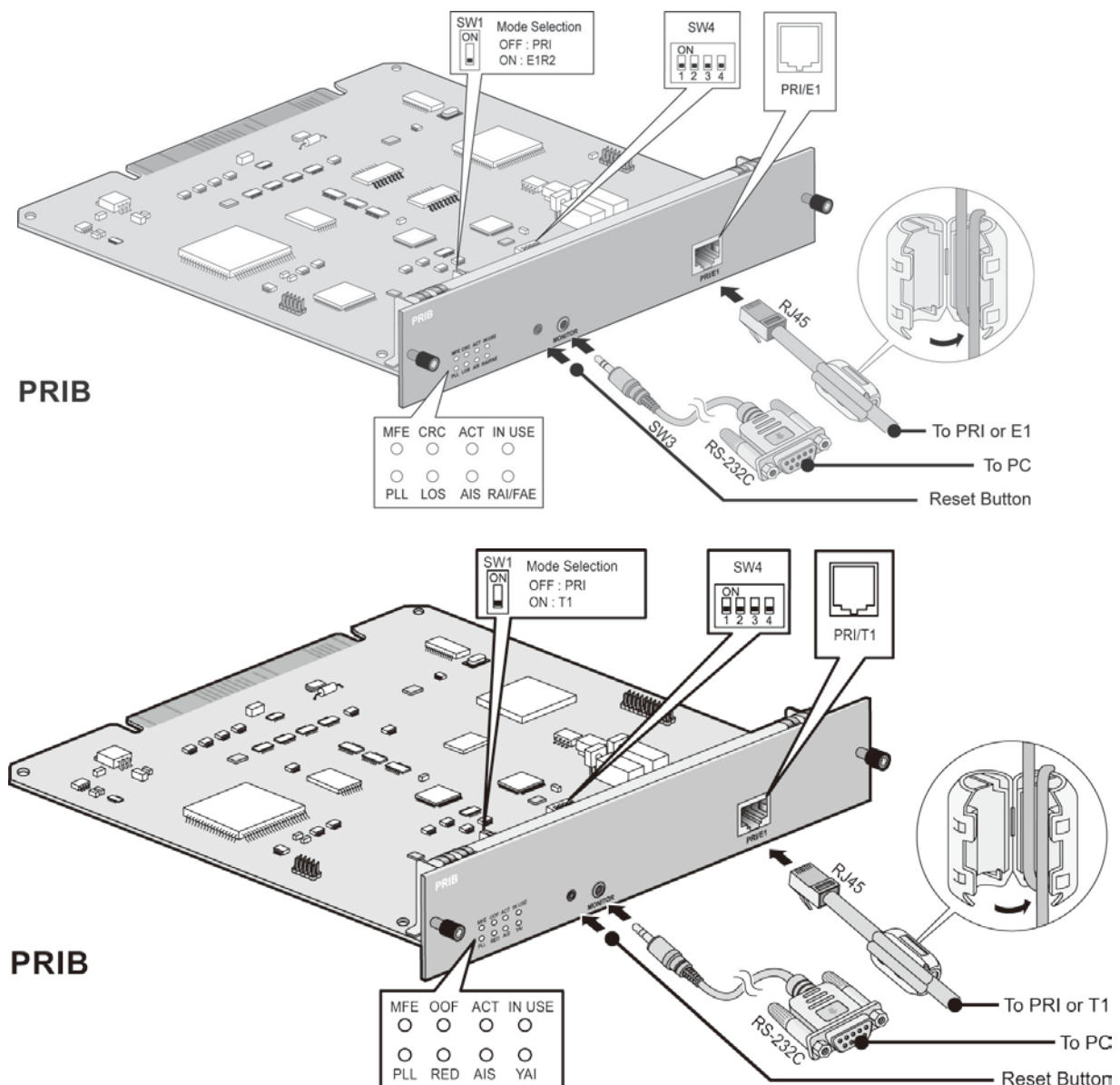

Figure 5.3.4-1 T1 PRIB

**NOTE**

iPECS-MG does not support daisy chained clocking for digital lines. The clock priority and synchronization is controlled by Admin. For details, refer to PGM 301 of the iPECS-MG Admin Manual.

The default clock is assigned based on the board type, KSU, and slot as below.

- Board – PRIB > BRIB2/BRIB4 > Internal Clock
- KSU – 1’st KSU > 2’nd KSU > 3’rd KSU
- Slot – Slot 1 > Slot 2 >...> Slot 18

**5.3.4.1 Switch and LED Functions**

**Table 5.3.4.1-1 Switch Functions**

SWITCH	FUNCTION	REMARK
SW1	Mode Selection (OFF = PRI, ON = T1)	Default: PRI mode
SW3	Reset switch	
SW4-1	Not used	
SW4-2	Not used	
SW4-3	Not used	
SW4-4	Not used	

**Table 5.3.4.1-2 LED Indication**

LED	FUNCTION	REMARK
PLL	PLL Synchronization	Red LED ON = Error OFF = Normal)
RDE	Red Alarm Indication)	
AIS	Alarm Indication Signal/Blue Alarm	
YAI	Yellow Alarm Indication	
MFE	Multi-frame Establish Alarm	
OOF	Out of Frame	
ACT	Activity Indication	Blue (Blink)
IN USE	Indication of channel use	Blue LED ON: Channels in use, OFF: All channels idle

**5.3.4.2 T1-PRIB Installation**

Before inserting the T1-PRIB, set SW1 and SW4 Dip switches to match the Telco provided service. Note that the PRIB supports ESF (Extended Super Frame) framing and B8ZS (Binary 8 Zero Substitution) line coding only. The T1-PRIB board can be installed in any universal slot of any KSU; the 1st slot of the BKSU is for the MPB only.

- Assure Power is OFF.
- Slide the PRIB in the guide rails of the desired slot.
- Tighten thumbscrews to hold the board firmly in place.

### 5.3.4.3 T1-PRIB Wiring

The T1-PRIB Transmit and Receive pairs are terminated in the PRI/T1 RJ45 connector. A single RJ45 is provided for the digital line interface.

Before wiring the PRIB, the Ferrite core provided with the T1-PRIB must be installed to reduce EMI (Elector-Magnetic Interference). To install the Ferrite core,

- Open the core.
- Insert and loop the RJ45 terminated cable for the T1-PRIB through the core as shown in Figure 5.3.4-1.
- Close the Ferrite core over the cable.

Referring to the pin-out chart and Figure 5.3.3.3-1 E1-PRIB Connector Wiring Diagram below,

- Wire the TX and RX pins of the RJ45 connector to the digital line termination point at the CSU using UTP cable.
- Tag or number wiring for maintenance.

**Table 5.3.4.3-1 T1 PRI Port**

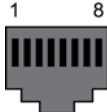
CONNECTOR	PIN	SIGNAL
RJ45 	1	RX+
	2	RX-
	4	TX+
	5	TX-
	3,6,7,8	Not used

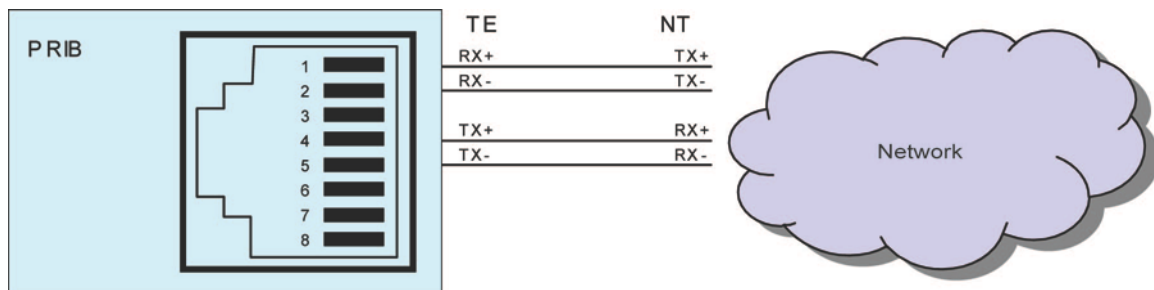

**Figure 5.3.4.3-1 T1-PRIB Connector Wiring Diagram**

### 5.3.4.4 Serial Port

The PRIB includes an Audio jack connected to a Serial port. The serial port is used for diagnostic purposes. For wiring information, refer to section 5.6.

## 5.4 Extension Boards

### 5.4.1 SLIB (Single Line Interface Board w/RJ45)

There are two kinds of SLIB12/SLIB24 according to CPU, but they have the same functions.

The SLIB is available in two (2) models, the SLIB 12 with 12 analog Single Line Telephone ports and the SLIB24 with 24 SLT ports. In both cases, the SLT ports are each terminated in an RJ45 connector. The SLIB provides FSK (ITU-T V.23 or Bell 202) or DTMF (ITU-T Q.23) Caller ID function to the SLT. The SLT ports provide the -48 VDC source, current limited to 20 mA, to operate the SLT and support the Message Wait Indication, DTMF, or Pulse Dial signaling, Polarity reversal, sinusoidal Ring generator, and GR-909 Line Testing.

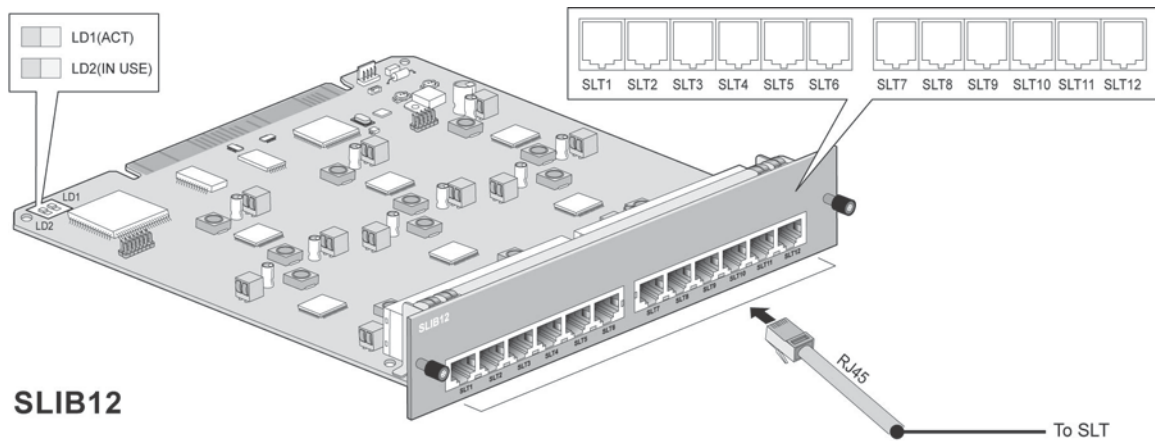

SLIB12

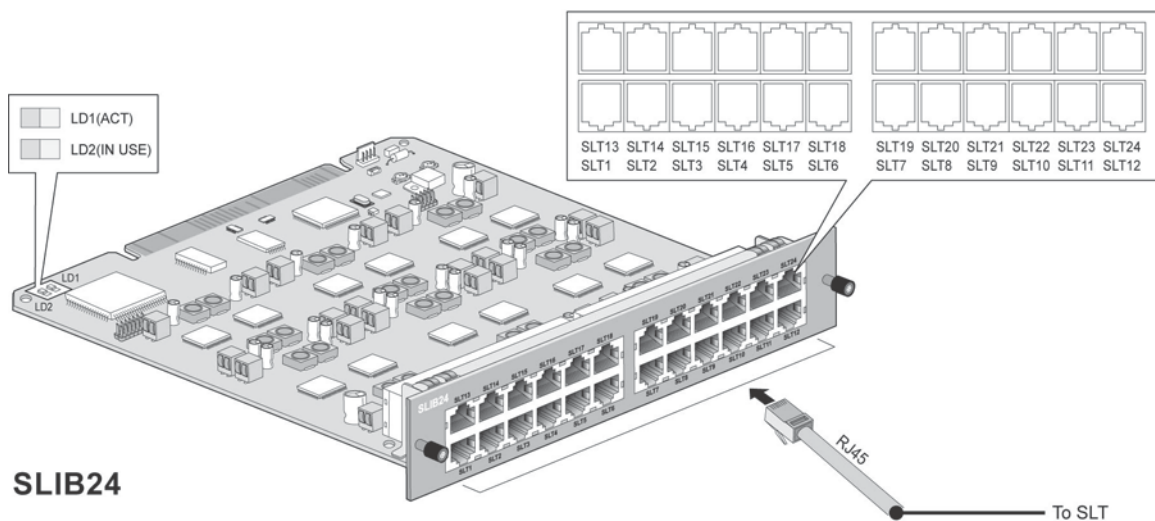

SLIB24



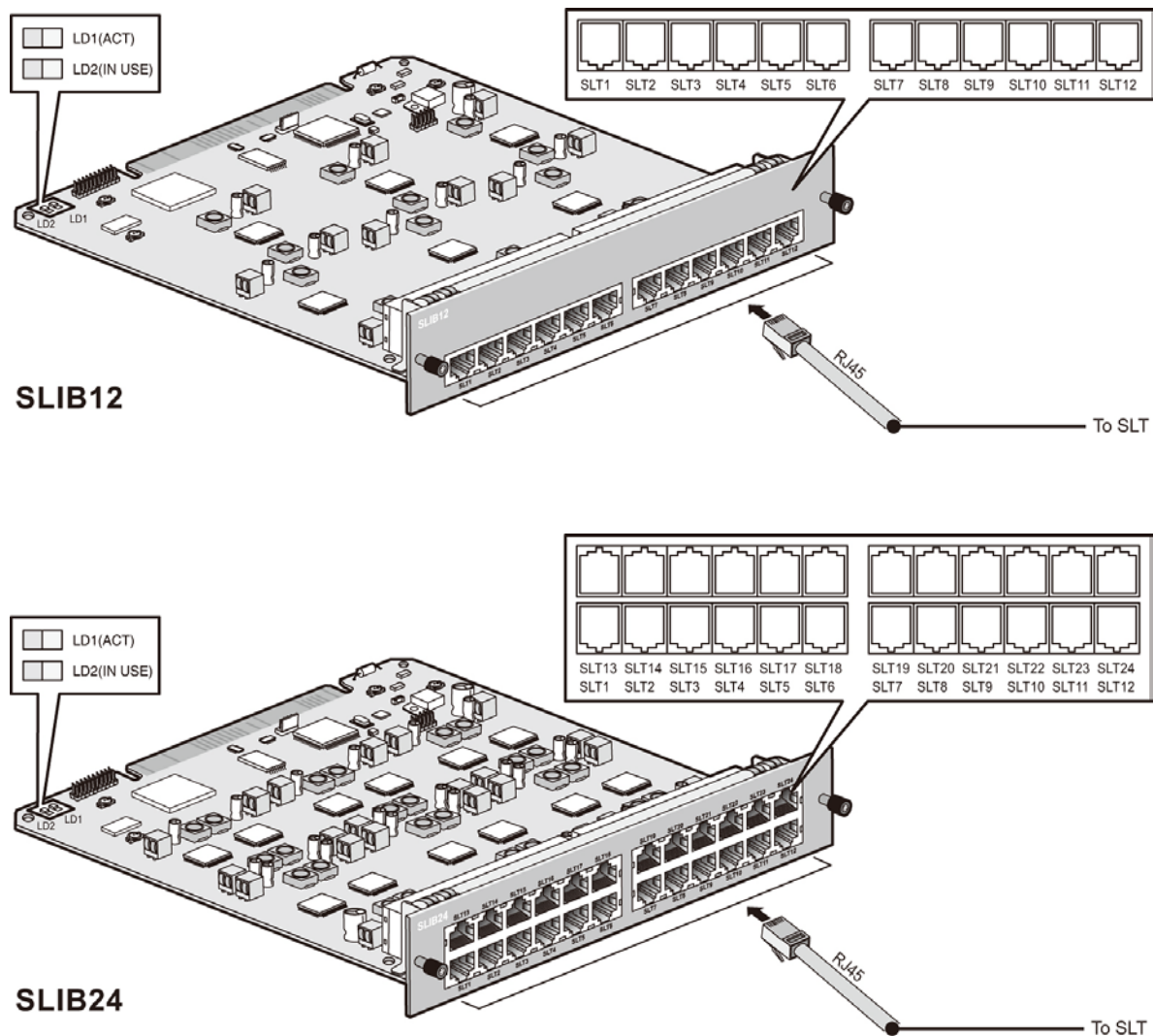

Figure 5.4.1-1 SLIB12/24

### 5.4.1.1 LED Functions

LED	FUNCTION	REMARK
LD1	ACT, Activation or Normal Operating	Blink (Blue Color)
LD2	IN USE	ON: one or ports in use OFF: All channels, Idle

### 5.4.1.2 SLIB Installation

The SLIB has no switches or connectors that are field useable. The SLIB can be installed in any universal slot of any KSU; the 1st slot of the BKSU is for the MPB only. Note a maximum of four (4) DTIB24/SLIB24s can be installed in a KSU.

- Assure Power is OFF.
- Slide the SLIB in the guide rails of the desired slot.
- Tighten thumbscrews to hold the board firmly in place.

### 5.4.1.3 SLIB Wiring

The SLT is terminated to the center pair of each RJ45 connector. A separate RJ45 is provided for each SLT port on the SLIB (12 or 24 connectors).

Referring to the pin-out chart below,

- Wire pins 4 and 5 of the RJ45 connector to the SLT termination point using UTP cable. The maximum total wire length is 7500M/24Kft of 22 AWG wire or 5000M/16Kft of 24 AWG wire. For information on wiring the SLT, refer to section 6.1.2.2.
- Tag or number wiring for maintenance.

**Table 5.4.1.3.1 SLIB 12/24**

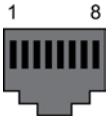
CONNECTOR	PIN	SIGNAL NAME	FUNCTION
RJ45 	1,2,3	Not used	
	4	SLT_RX	Receive Data
	5	SLT_TX	Transmit Data
	6,7,8	Not used	

### 5.4.2 SLIBC (Single Line Interface Board w/RJ21)

There are two kinds of SLIB12C/SLIB24C according to CPU, but they have the same functions.

The SLIBC is available in two (2) models, the SLIB12C with 12 SLT ports and the SLIB24C with 24 SLT ports. The SLIBC is identical to the SLIB except the SLT ports of the SLIBC are terminated in a 25-pair RJ21 female connector. The SLIBC provides FSK (ITU-T V.23 or Bell 202) or DTMF (ITU-T Q.23) Caller ID function to the SLT. The SLT ports provide the -48 VDC source, current limited to 20 mA, to operate the SLT and support the Message Wait Indication, DTMF, or Pulse Dial signaling, Polarity reversal, sinusoidal Ring generator, and GR-909 Line Testing.

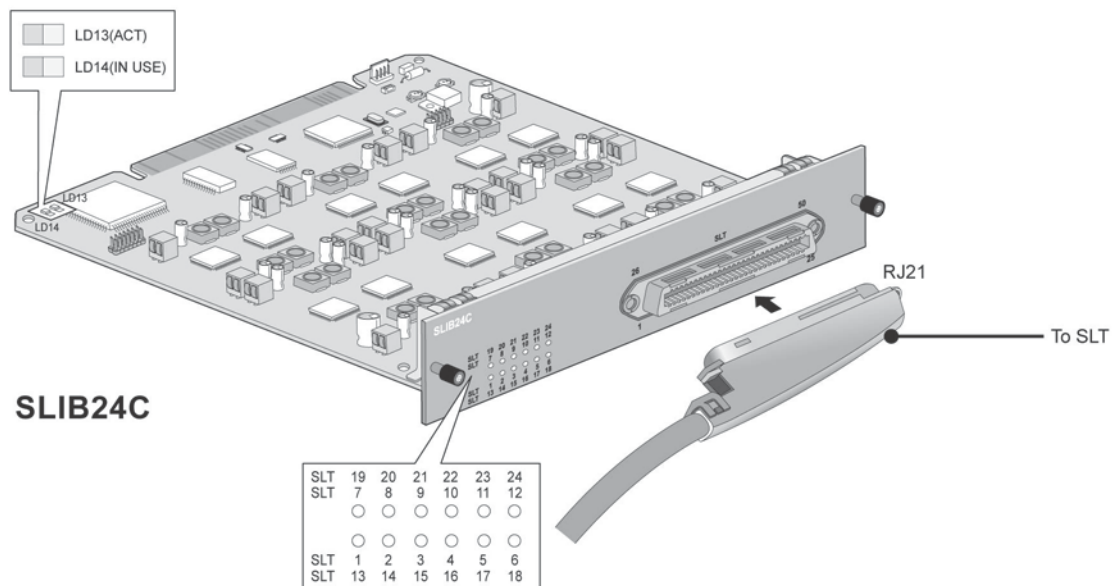
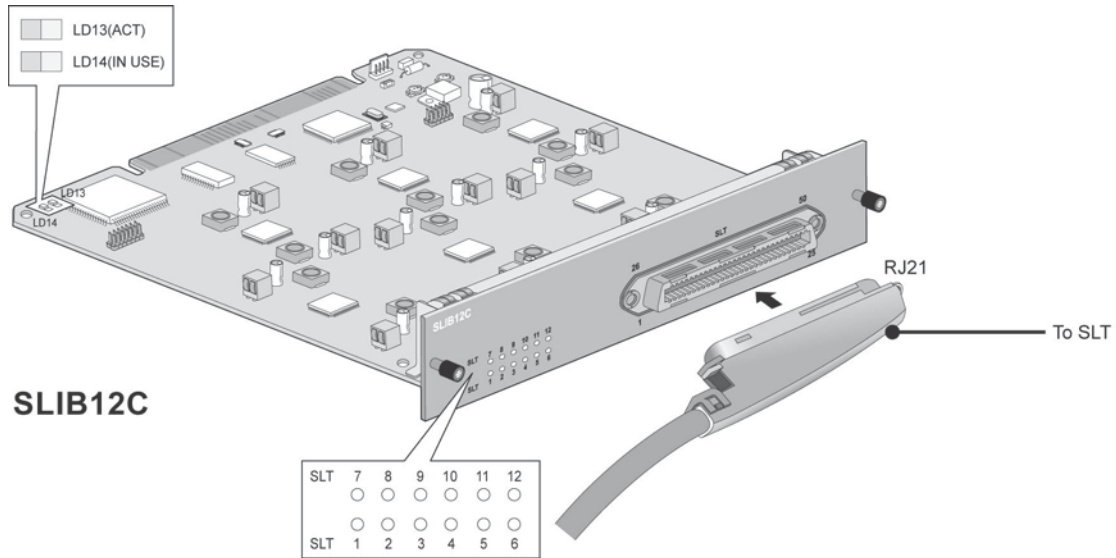

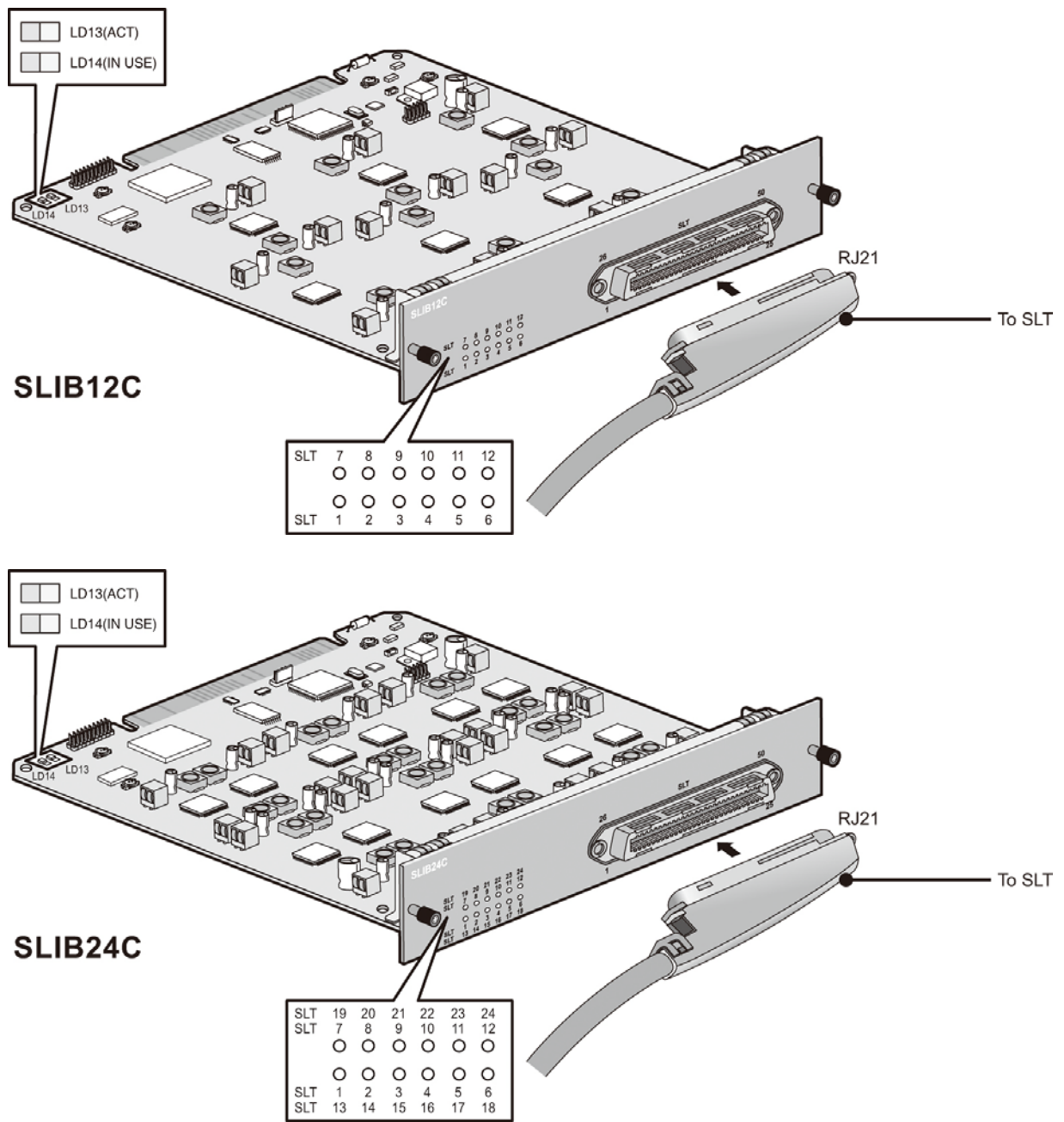

Figure 5.4.2-1 SLIB12/24C

### 5.4.2.1 LED Functions

**Table 5.4.2.1-1 LED Indications**

LED	FUNCTION	REMARK
LD1	The status of 1 <sup>st</sup> port or 13 <sup>th</sup> port	ON (Blue) : 1 <sup>st</sup> port in use ON (Yellow Green) : 13 <sup>th</sup> port in use ON (Blush white) : 1 <sup>st</sup> and 13 <sup>th</sup> port in use OFF: Idle
LD2	The status of 2 <sup>nd</sup> port or 14 <sup>th</sup> port	ON (Blue) : 2 <sup>nd</sup> port in use ON (Yellow Green) : 14 <sup>th</sup> port in use ON (Blush white) : 2 <sup>nd</sup> and 14 <sup>th</sup> port in use OFF: Idle
LD3	The status of 3 <sup>rd</sup> port or 15 <sup>th</sup> port	ON (Blue) : 3 <sup>rd</sup> port in use ON (Yellow Green) : 15 <sup>th</sup> port in use ON (Blush white) : 3 <sup>rd</sup> and 15 <sup>th</sup> port in use OFF: Idle
LD4	The status of 4 <sup>th</sup> port or 16 <sup>th</sup> port	ON (Blue) : 4 <sup>th</sup> port in use ON (Yellow Green) : 16 <sup>th</sup> port in use ON (Blush white) : 4 <sup>th</sup> and 16 <sup>th</sup> port in use OFF: Idle
LD5	The status of 5 <sup>th</sup> port or 17 <sup>th</sup> port	ON (Blue) : 5 <sup>th</sup> port in use ON (Yellow Green) : 17 <sup>th</sup> port in use ON (Blush white) : 5 <sup>th</sup> and 17 <sup>th</sup> port in use OFF: Idle
LD6	The status of 6 <sup>th</sup> port or 18 <sup>th</sup> port	ON (Blue) : 6 <sup>th</sup> port in use ON (Yellow Green) : 18 <sup>th</sup> port in use ON (Blush white) : 6 <sup>th</sup> and 18 <sup>th</sup> port in use OFF: Idle
LD7	The status of 7 <sup>th</sup> port or 19 <sup>th</sup> port	ON (Blue) : 7 <sup>th</sup> port in use ON (Yellow Green) : 19 <sup>th</sup> port in use ON (Blush white) : 7 <sup>th</sup> and 19 <sup>th</sup> port in use OFF: Idle
LD8	The status of 8 <sup>th</sup> port or 20 <sup>th</sup> port	ON (Blue) : 8 <sup>th</sup> port in use ON (Yellow Green) : 20 <sup>th</sup> port in use ON (Blush white) : 8 <sup>th</sup> and 20 <sup>th</sup> port in use OFF: Idle
LD9	The status of 9 <sup>th</sup> port or 21 <sup>st</sup> port	ON (Blue) : 9 <sup>th</sup> port in use ON (Yellow Green) : 21 <sup>st</sup> port in use ON (Blush white) : 9 <sup>th</sup> and 21 <sup>st</sup> port in use OFF: Idle
LD10	The status of 10 <sup>th</sup> port or 22 <sup>nd</sup> port	ON (Blue) : 10 <sup>th</sup> port in use ON (Yellow Green) : 22 <sup>nd</sup> port in use ON (Blush white) : 10 <sup>th</sup> and 22 <sup>nd</sup> port in use OFF: Idle

**Table 5.4.2.1-1 LED Indications**

LED	FUNCTION	REMARK
LD11	The status of 11 <sup>th</sup> port or 23 <sup>rd</sup> port	ON (Blue) : 11 <sup>th</sup> port Use ON (Yellow Green) : 23 <sup>rd</sup> port in use ON (Blush white) : 11 <sup>th</sup> and 23 <sup>rd</sup> port in use OFF: Idle
LD12	The status of 12 <sup>th</sup> port or 24 <sup>th</sup> port	ON (Blue) : 12 <sup>th</sup> port in use ON (Yellow Green) : 24 <sup>th</sup> port in use ON (Blush white) : 12 <sup>th</sup> and 24 <sup>th</sup> port in use OFF: Idle
LD13	ACT, Activation or Normal Operating	Blink (Blue Color)
LD14	In use	ON: Ch. Use, OFF: All channels Idle

### 5.4.2.2 SLIBC Installation

The SLIB has no switches or connectors that are field useable. The SLIB can be installed in any universal slot of any KSU; the 1st slot of the BKSU is for the MPB only. Note a maximum of four (4) DTIB24/SLIB24Cs can be installed in a KSU.

- Assure Power is OFF
- Slide the SLIBC in the guide rails of the desired slot.
- Tighten thumbscrews to hold the board firmly in place.

### 5.4.2.3 SLIBC Wiring

Each SLT port is terminated to a pair in the RJ21 connector. SLT 1 is terminated at pair 1, SLT 2 is terminated on pair 2, etc. to the number of ports (12 or 24) on the SLIBC.

Referring to the pin-out chart below,

- Wire each SLT pair on the RJ21 connector to the SLT termination point using UTP cable. The maximum total wire length is 7500M/24Kft of 22 AWG wire or 5000M/16Kft of 24 AWG wire. For information on wiring the SLT, refer to section 6.1.2.2
- Tag or number wiring for maintenance.

Table 5.4.2.1-2 SLIBC Pin-Out Chart

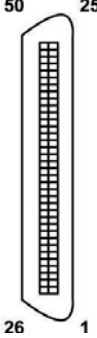
CONNECTOR	PIN		COLOR CODE	SLIB PORT
	VT	VR		
RJ21  	1	26		1
	2	27		2
	3	28		3
	4	29		4
	5	30		5
	6	31		6
	7	32		7
	8	33		8
	9	34		9
	10	35		10
	11	36		11
	12	37		12
	13	38		13
	14	39		14
	15	40		15
	16	41		16
	17	42		17
	18	43		18
	19	44		19
	20	45		20
	21	46		21
	22	47		22
	23	48		23
	24	49		24
	25	50		

### 5.4.3 DTIB (Digital Terminal Interface Board w/RJ-45)

The DTIB is available in two (2) models, the DTIB12 with 12 Digital Key Telephone Interface ports and the DTIB24 with 24 DKT ports. Each port provides power and signaling to the DKT over a single wire pair. Each DKT port of the DTIB is terminated in an RJ45 connector on the front panel of the DTIB.

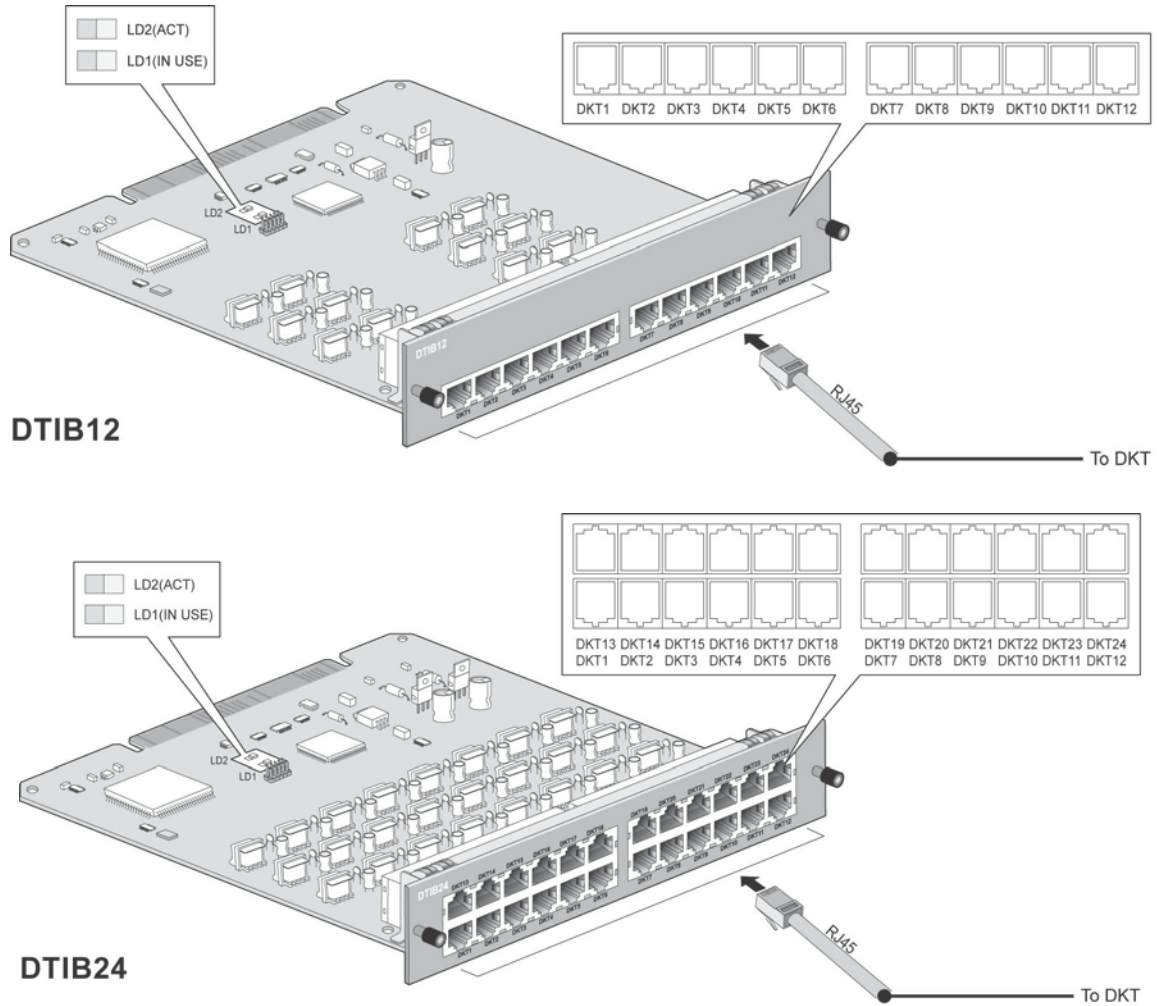

Figure 5.4.3-1 DTIB (Digital Telephone Interface Board)



### 5.4.3.1 LED Functions

**Table 5.4.5.1-1 LED Indication**

LED	FUNCTIONS	REMARK
LD1	IN USE	ON: Channel in use, OFF: All channels Idle
LD2	ACT, Activation or Normal Operating	Blink (Blue Color)

### 5.4.3.2 DTIB Installation

The DTIB has no switches or connectors that are field useable. The DTIB can be installed in any universal slot of any KSU; the 1st slot of the BKSU is for the MPB only. Note a maximum of four (4) DTIB24/SLIB24s can be installed in a KSU.

- Assure Power is OFF
- Slide the DTIB in the guide rails of the desired slot.
- Tighten thumbscrews to hold the board firmly in place.

### 5.4.3.3 DTIB Wiring

A separate RJ45 is provided for each DKT port on the DTIB (12 or 24 connectors). DKT ports terminate on the center pair of the RJ45 connectors.

Referring to the pin-out chart below,

- Wire pins 4 and 5 of the RJ45 connector to the DKT termination point using UTP cable. The maximum total wire length is 500M/1.6Kft of 22 AWG or 330M/1Kft of 24 AWG wire. For information on wiring the Digital Key Telephone, refer to section 6.1.2.1
- Tag or number wiring for maintenance.

**Table 5.4.5.3-1 DTIB RJ45 Pin-Out Chart**

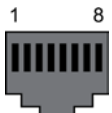
CONNECTOR	PIN	SIGNAL NAME	FUNCTION
RJ45 	1,2,3	Not used	
	4	DKT_RX	Receive Data
	5	DKT_TX	Transmit Data
	6,7,8	Not used	

### 5.4.4 DTIBC (Digital Telephone Interface Board w/RJ21 connector)

The DTIBC is available in two (2) models, the DTIB12 with 12 Digital Key Telephone Interface ports and the DTIB24 with 24 DKT ports. The DTIBC is identical to the DTIB except the DKT ports of the DTIBC are terminated to an RJ21 connector. Each port provides power and signaling to the DKT over a single wire pair.

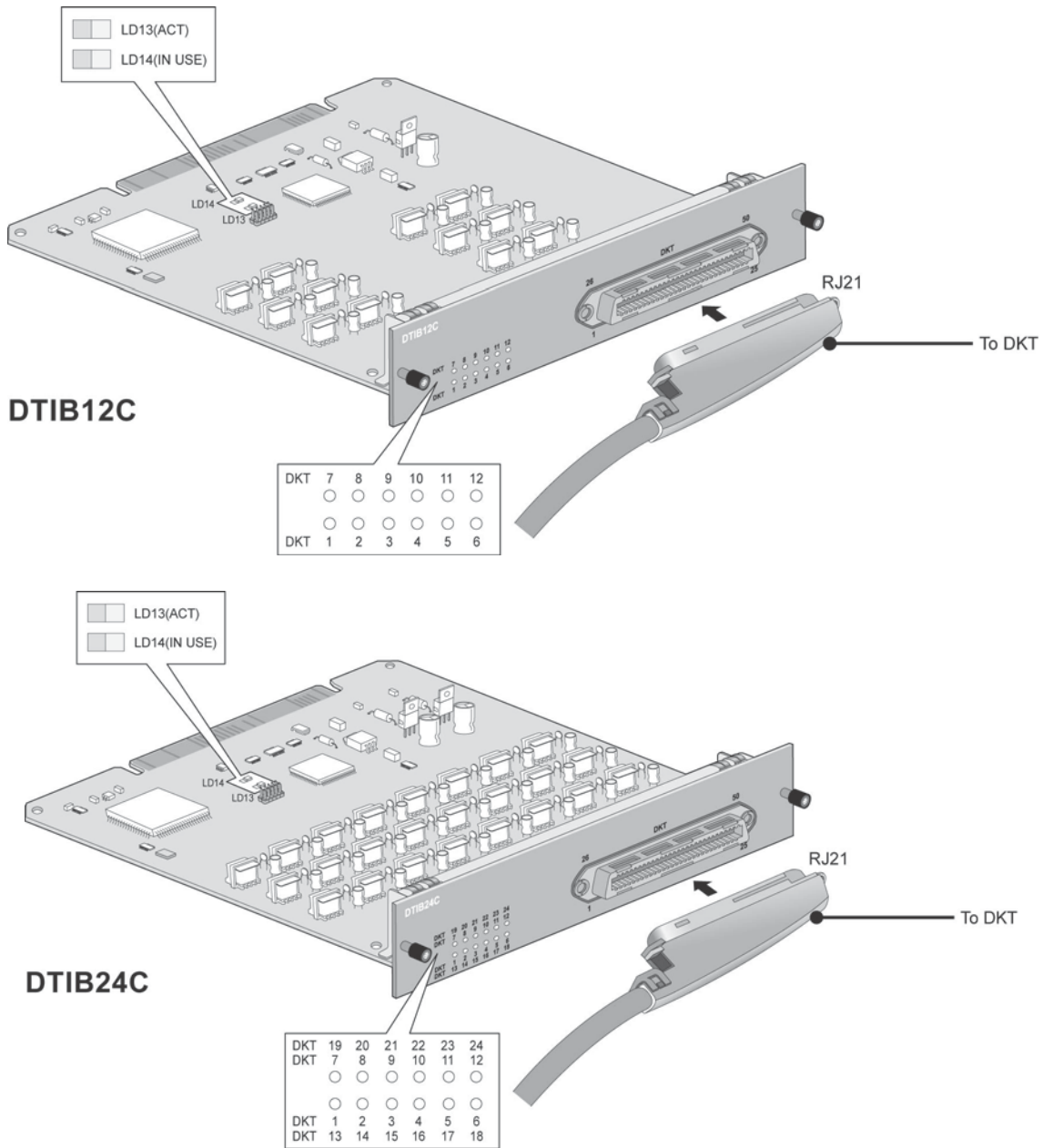

Figure 5.4.4-1 DTIB Digital Telephone Interface Board

### 5.4.4.1 LED Functions

**Table 5.4.6.1-1 LED Indication**

LED	FUNCTION	REMARK
LD1	The status of 1 <sup>st</sup> port or 13 <sup>th</sup> port	ON (Blue) : 1 <sup>st</sup> port Use ON (Yellow Green) : 13 <sup>th</sup> port Use ON (Blush white) : 1 <sup>st</sup> and 13 <sup>th</sup> port Use OFF: Idle
LD2	The status of 2 <sup>nd</sup> port or 14 <sup>th</sup> port	ON (Blue) : 2 <sup>nd</sup> port Use ON (Yellow Green) : 14 <sup>th</sup> port Use ON (Blush white) : 2 <sup>nd</sup> and 14 <sup>th</sup> port Use OFF: Idle
LD3	The status of 3 <sup>rd</sup> port or 15 <sup>th</sup> port	ON (Blue) : 3 <sup>rd</sup> port Use ON (Yellow Green) : 15 <sup>th</sup> port Use ON (Blush white) : 3 <sup>rd</sup> and 15 <sup>th</sup> port Use OFF: Idle
LD4	The status of 4 <sup>th</sup> port or 16 <sup>th</sup> port	ON (Blue) : 4 <sup>th</sup> port Use ON (Yellow Green) : 16 <sup>th</sup> port Use ON (Blush white) : 4 <sup>th</sup> and 16 <sup>th</sup> port Use OFF: Idle
LD5	The status of 5 <sup>th</sup> port or 17 <sup>th</sup> port	ON (Blue) : 5 <sup>th</sup> port Use ON (Yellow Green) : 17 <sup>th</sup> port Use ON (Blush white) : 5 <sup>th</sup> and 17 <sup>th</sup> port Use OFF: Idle
LD6	The status of 6 <sup>th</sup> port or 18 <sup>th</sup> port	ON (Blue) : 6 <sup>th</sup> port Use ON (Yellow Green) : 18 <sup>th</sup> port Use ON (Blush white) : 6 <sup>th</sup> and 18 <sup>th</sup> port Use OFF: Idle
LD7	The status of 7 <sup>th</sup> port or 19 <sup>th</sup> port	ON (Blue) : 7 <sup>th</sup> port Use ON (Yellow Green) : 19 <sup>th</sup> port Use ON (Blush white) : 7 <sup>th</sup> and 19 <sup>th</sup> port Use OFF: Idle
LD8	The status of 8 <sup>th</sup> port or 20 <sup>th</sup> port	ON (Blue) : 8 <sup>th</sup> port Use ON (Yellow Green) : 20 <sup>th</sup> port Use ON (Blush white) : 8 <sup>th</sup> and 20 <sup>th</sup> port Use OFF: Idle
LD9	The status of 9 <sup>th</sup> port or 21 <sup>st</sup> port	ON (Blue) : 9 <sup>th</sup> port Use ON (Yellow Green) : 21 <sup>st</sup> port Use ON (Blush white) : 9 <sup>th</sup> and 21 <sup>st</sup> port Use OFF: Idle
LD10	The status of 10 <sup>th</sup> port or 22 <sup>nd</sup> port	ON (Blue) : 10 <sup>th</sup> port Use ON (Yellow Green) : 22 <sup>nd</sup> port Use ON (Blush white) : 10 <sup>th</sup> and 22 <sup>nd</sup> port Use OFF: Idle

**Table 5.4.6.1-1 LED Indication**

LED	FUNCTION	REMARK
LD11	The status of 11 <sup>th</sup> port or 23 <sup>rd</sup> port	ON (Blue) : 11 <sup>th</sup> port Use ON (Yellow Green) : 23 <sup>rd</sup> port Use ON (Blush white) : 11 <sup>th</sup> and 23 <sup>rd</sup> port Use OFF: Idle
LD12	The status of 12 <sup>th</sup> port or 24 <sup>th</sup> port	ON (Blue) : 12 <sup>th</sup> port Use ON (Yellow Green) : 24 <sup>th</sup> port Use ON (Blush white) : 12 <sup>th</sup> and 24 <sup>th</sup> port Use OFF: Idle
LD13	ACT, Activation or Normal Operating	Blink (Blue Color)
LD14	In use	ON: Ch. Use, OFF: All channels Idle

#### 5.4.4.2 DTIBC Installation

The DTIBC has no switches or connectors that are field useable. The DTIBC can be installed in any universal slot of any KSU; the 1st slot of the BKSU is for the MPB only. Note a maximum of four (4) DTIB24C/SLIB24s can be installed in a KSU.

- Assure Power is OFF
- Slide the DTIBC in the guide rails of the desired slot.
- Tighten thumbscrews to hold the board firmly in place.

#### 5.4.4.3 DTIBC Wiring

Each DKT port is terminated to a pair in the RJ21 connector. DKT 1 is terminated at pair 1, DKT 2 is terminated on pair 2, etc. to the number of ports (12 or 24) on the DTIBC.

Referring to the pin-out chart below,

- Wire each DKT pair on the RJ21 connector to the DKT termination point using UTP cable. The maximum total wire length is 500M/1.6Kft of 22 AWG or 330M/1Kft of 24 AWG wire. For information on wiring the DKT, refer to section 6.1.2.1.
- Tag or number wiring for maintenance.

**Table 5.4.6.4-1 DTIBC Pin-out Chart**

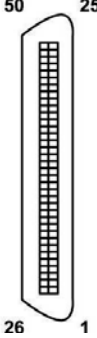
CONNECTOR	PIN		COLOR CODE	SLIB PORT
	VT	VR		
RJ21  	1	26		1
	2	27		2
	3	28		3
	4	29		4
	5	30		5
	6	31		6
	7	32		7
	8	33		8
	9	34		9
	10	35		10
	11	36		11
	12	37		12
	13	38		13
	14	39		14
	15	40		15
	16	41		16
	17	42		17
	18	43		18
	19	44		19
	20	45		20
	21	46		21
	22	47		22
	23	48		23
	24	49		24
	25	50		

### 5.4.5 WTIB (Wireless Telephone Interface Board) for DECT

The WTIB is the iPECS-MG interface to the System DECT solution for in-building mobility with transparent handover. The WTIB supports European DECT and is not intended for use in other regions. The System DECT solution is comprised of the 4 or 8 port Wireless Telephone Interface Boards (WTIB4/8), System DECT Base Stations providing the fixed radio receivers (cells), and DECT handsets. The figure below is a reference model of the iPECS-MG System DECT solution.

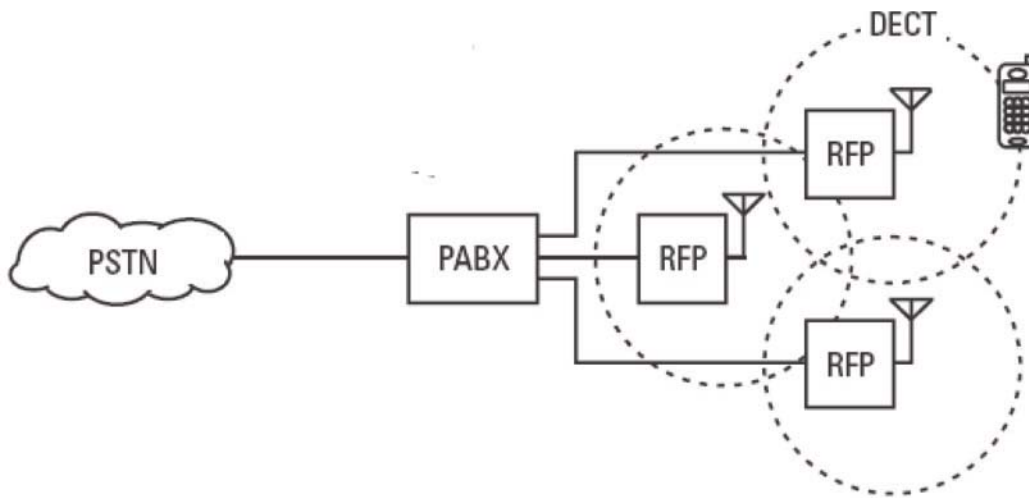

**Figure 5.4.5-1 iPECS-MG DECT Reference Model**

The following components make up the System DECT solution:

- WTIB4, WTIB8 board – Up to three WTIB4s or WTIB8s can be installed in the iPECS-MG300, 2 in the MG100 System. The WTIB4 and WTIB8 have 4 or 8 Base Station ports, respectively.
- Base Station (GDC-600B/GDC-600BE) – The System DECT Base Station can process up to six simultaneous calls. The Base Station is intended for indoor use only.
- Wireless Terminal (GDC-400H/450H) – Up to 192 wireless terminals can be registered (refer to the DECT Wireless Terminal User Guide). Older versions may be compatible, check with your local representative.

**Table 5.4.5-1 System DECT Base Station Specifications**

ITEM	SPECIFICATION
Power Feed required	+30 VDC
Transmission Max Power	250 mW
Access Method/Duplex	TDMA/TDD
Frequency Band	1,880 ~ 1,900MHz
Channel Spacing	1.728MHz
Modulation	GFSK
Data Rate	1.152Mbps
Max. Base Station distance from the WTIB4/8	600m (twisted 2-pair cable)
Max. Transmission Power	250 mW
Modulation Method	GFSK
Frequency Band	1,880MHz ~ 1,900MHz

The WTIB provides power to the System DECT Base Stations and is the interface between Base Stations and other resources and features of the iPECS-MG. The iPECS-MG100 supports two (2) WTIBs and the iPECS-MG300 will support three (3) WTIBs. Each port on the WTIB terminates to an RJ45 connector on the front panel of the board.

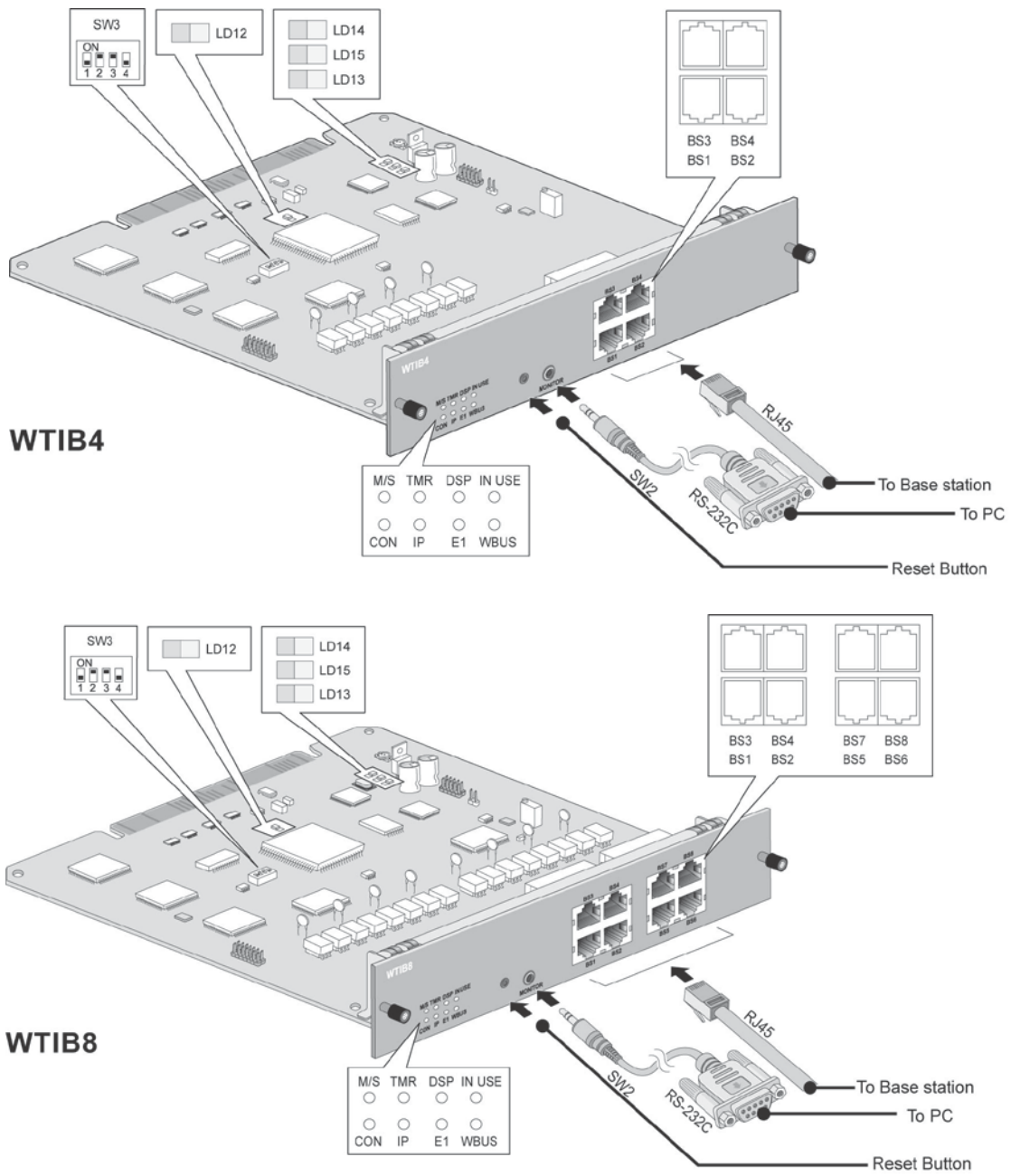

Figure 5.4.5-2 WTIB (Wireless Telephone Interface Board)



### 5.4.5.1 Connectors, Switch and LED Functions

The following Table shows the relation between the front panel RJ45 connectors and associated Base Station (cell) numbers.

**Table 5.4.5.1-1 WTIB RJ45 Connector Functions**

CONNECTOR	CELL NUMBER
BS1	Cell 1
BS2	Cell 2
BS3	Cell 3
BS4	Cell 4
BS5, WTIB8 only	Cell 5
BS6, WTIB8 only	Cell 6
BS7, WTIB8 only	Cell 7
BS8, WTIB8 only	Cell 8

**Table 5.4.5.1-2 Switch Functions**

SWITCH	ON	OFF	DESCRIPTION	DEFAULT
SW3-1	Test mode	Normal	TRB6 Test Mode	OFF
SW3-2	Enable Echo-can.	Disable Echo-can.	Echo-canceller control	ON
SW3-3			Not used	ON
SW3-4	All base reset	Only new base reset	On: All base reset Off: One base reset	OFF

The nine (9) LEDs mounted on the WTIB indicate the status of the board as explained in the chart below.

**Table 5.4.5.1-3 WTIB LED Indications**

LED	NORMAL	LABEL
1	ON: Master WTIB, Toggle: Slave 1 WTIB, OFF: Slave 2 WTIB	M/S
2	When Nios CPU is normal, TMR LED toggles every 100msec.	TMR
3	ON: DSP Echo cancellation enabled, OFF: DSP Echo cancellation disabled	DSP
4	When more than one DECT channel is used, LED8 is ON.	IN USE
5	When WTIB is connected with MPB, CON LED is ON.	CON
6	When WTIB sends or receives data from MPB, IP LED toggles.	IP
7	When WTIB sends or receives data from Base Station, E1 LED toggles.	E1
8	When WTIB sends or receives data from other WTIB, WBUS LED toggles.	WBUS

### 5.4.5.2 DECT Installation

For detailed instructions on Site Planning for Base Stations, Cell-coverage Region Survey, RSSI Monitoring, and Base Station Installation, refer to the DECT Installation Guide for iPECS-MG.

### 5.4.5.3 WTIB Installation

Prior to installation, assure the Dipswitch settings are in the default position, section 5.4.5.1. The WTIB can be installed in any universal slot of any KSU; the 1st slot of the BKSU is for the MPB only. Note when installing more than one WTIB, all WTIBs should be installed in the same KSU.

- Assure Power is OFF.
- Slide the WTIB in the guide rails of the desired slot.
- Tighten thumbscrews to hold the board firmly in place.

### 5.4.5.4 Ferrite Core Installation

A ferrite core is provided in the packaging of the System DECT Base Station. When properly installed, the ferrite core reduces Electro-Magnetic Interference from the Base Station. The Ferrite core should be installed on each cable that is connected to the WTIB as close to the WTIB connector as possible. Using RJ45 terminate CAT3 cable, wrap the Ferrite core as shown in Figure 5.4.5.4-1.

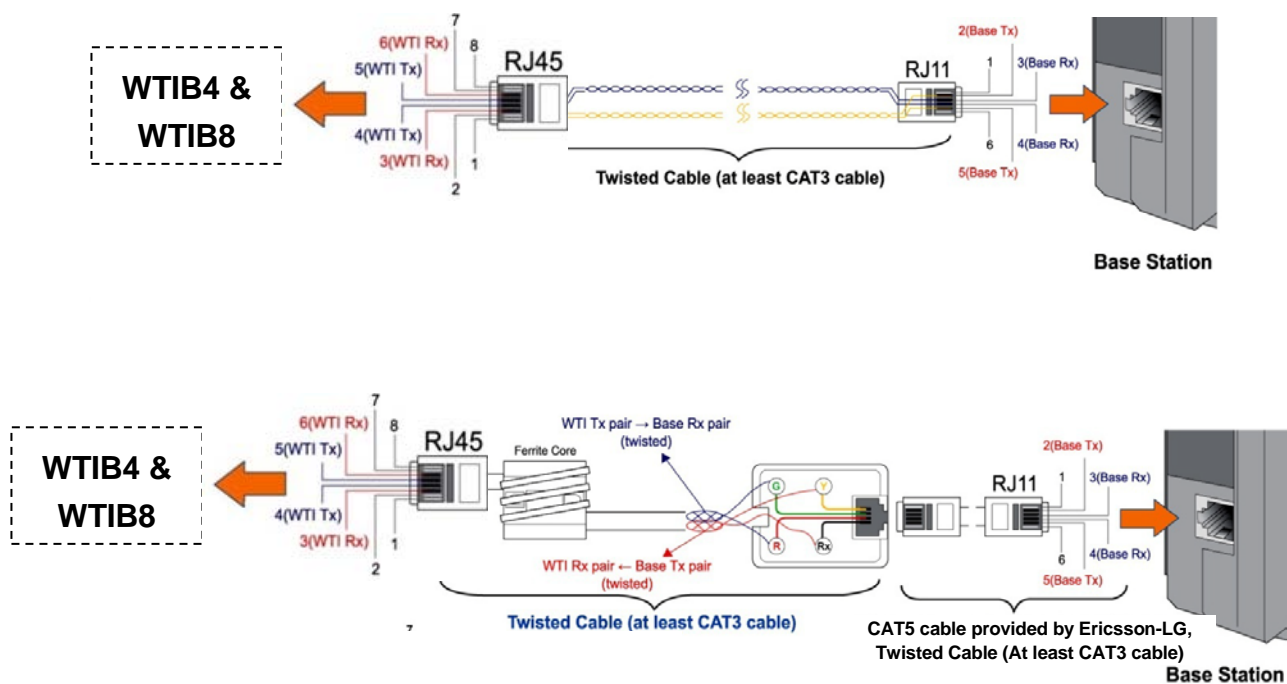

Figure 5.4.5.4-1 WTIB Ferrite Core and Base Station

### 5.4.5.5 WTIB Wiring

Each Base Station port on the WTIB is terminated to an RJ45 connector wired as shown in the pin-out chart below. Separate wiring is required for the TX and RX pairs. Power is delivered from the WTIB to the Base Station over the simplex circuit formed by the TX and RX pairs.

Referring to the pin-out charts and Figure 5.4.5.5-1 below and Figure 5.4.5.4-1,

- Plug RJ45 terminated cable with the Ferrite core into the appropriate WTIB connector.
- Wire each WTIB RJ45 TX and RX pair to the System DECT Base Station termination point using CAT3 or better wiring. The maximum total wire length is 600M/1.9Kft of 22 AWG.
- Tag or number wiring for maintenance.

#### NOTE

1. A shorter cable length between the WTIB and System DECT Base Stations will decrease the possibility of data degradation.
2. For best operation, all wiring from the WTIB to the Base Stations should use unshielded twisted pair wiring (at least Cat 3) of a consistent gauge and kept at the shortest length possible.

**Table 5.4.5.5-1 WTIB Pin-out Chart**

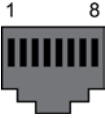
CONNECTOR	PIN	SIGNAL NAME	FUNCTION
RJ45 	1, 2, 7, 8	Not used	
	4	TX- & (+30V)	Transmit Data & +30VDC power
	5	TX+ & (+30v)	
	3	RX+(GND)	Receive Data & Gnd Power feed
	6	RX-(GND)	

**Table 5.4.5.5-2 Base Station**

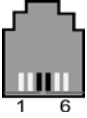
CONNECTOR	PIN	SIGNAL NAME	FUNCTION
RJ45 	5, 6	Not used	
	1	TX+ (GND)	Transmit Data & Gnd Power feed
	4	TX- (GND)	
	2	RX+ & (+30V)	Receive Data & +30VDC power
	3	RX- & (+30V)	

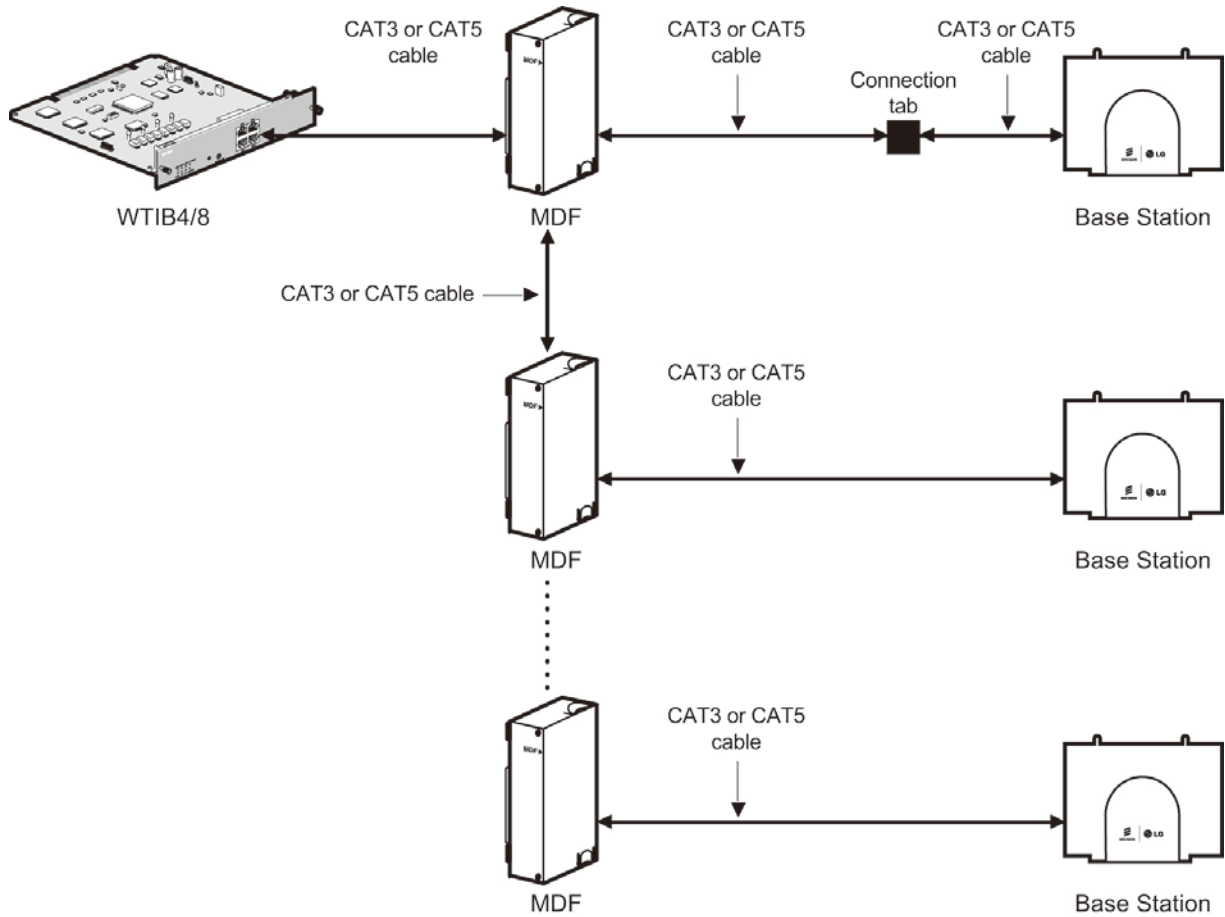

Figure 5.4.5.5-1 WTIB Connection to Multiple System DECT Base Stations

### 5.4.5.6 Serial Port

The VMIB an AAIB include an Audio jack connected to a Serial port. The serial port is used for diagnostic purposes. For wiring information, refer to section 5.6.

## 5.5 Function Boards

### 5.5.1 VMIB (Voice Mail Interface Board) and AAIB (Auto-Attendant Interface Board)

The VMIB and AAIB provide memory for System Greetings including CCR and ACD/UCD announcements. In addition, the VMIB provides memory for User Greetings and Voice Message storage, 100 hours. The VMIB and AAIB include a processor and DSP circuitry to support eight (8) simultaneous channels. For additional channels and/or storage capacity, two (2) VMIBs or AAIBs may be installed in the iPECS-MG100 (16 total channels) and up to three (3) VMIBs or AAIBs may be installed in the iPECS-MG 300 (24 total channels).

BOARD	CHANNEL	SYSTEM GREETING USER GREETING
VMIB	8	System Greeting (0.5hrs.), User Message (100 Hours)
AAIB	8	System Greeting (0.5hrs.), User Message (None)

The VMIB and AAIB have a standard USB connector that is used to back-up System and User greetings, and Voice Messages (VMIB only). In addition, the VMIB and AAIB have a LAN and Audio Serial port jack used for advanced diagnostic purposes and board upgrades only.

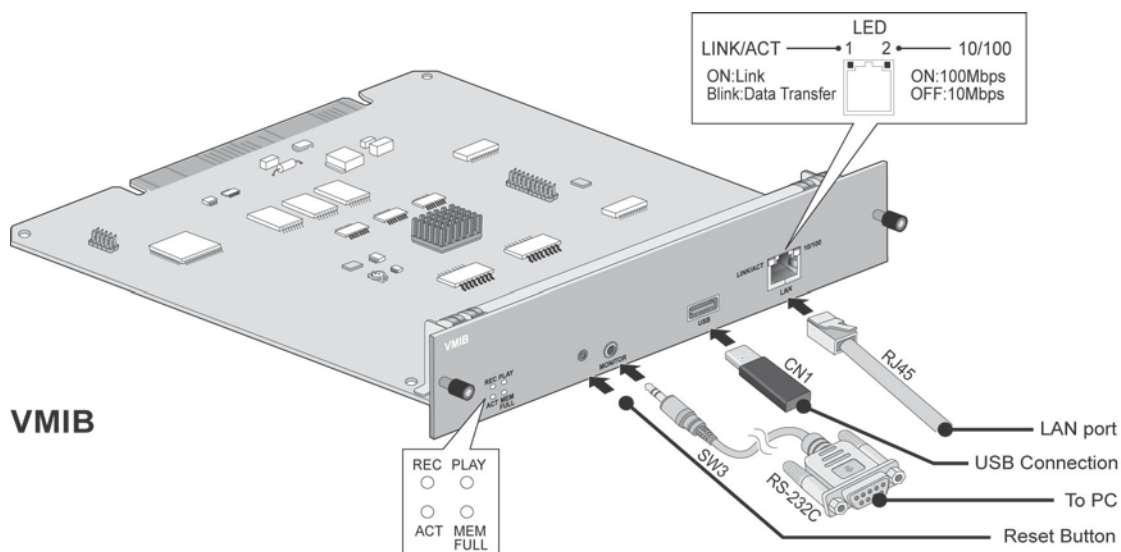

Figure 5.5.1-1 AAIB and VMIB

#### NOTE

- If VMIB or AAIB is installed in a System, VMIB/AAIB prompts (Default=1-English, 2-3-Blank) should be uploaded for each country.
- System Voice prompts are stored on the MPB and not the VMIB or AAIB.
- Voice prompt Language can be changed using the Web Admin, VMIB upgrade function.

### 5.5.1.1 Switch, and LED Functions

**Table 5.5.1.1-1 Switch Functions**

SWITCH	FUNCTION	REMARK
SW1	4-POLE Dip Switch (Function : not defined)	Default: Off
SW2		
SW3	Reset switch	
SW4		

**Table 5.5.1.1-2 LED Indication**

LED	FUNCTION	REMARK
LD1	Normal operation indication (Activity Indication)	Blink (blue Color)
LD2	Memory Full (ON – Full, OFF – Usable)	AAIB – Not used
LD3	Record (ON – Active, OFF – Idle)	
LD4	Play (ON – Active, OFF – Idle)	
RJ45-LD1 (Green/Orange)	ON – Link, Blink – Data Transfer	
RJ45-LD2 (Yellow)	ON - 100Mbps, OFF – 10Mbps	

### 5.5.1.2 VMIB and AAIB Installation

The VMIB and AAIB have no switches or connectors that are field useable. The VMIB and AAIB can be installed in any universal slot of any KSU; the 1st slot of the BKSU is for the MPB only. A maximum of two boards may be installed in the iPECS-MG100 and three (3) in the iPECS-MG300.

- Assure Power is OFF
- Slide the VMIB/AAIB in the guide rails of the desired slot.
- Tighten thumbscrews to hold the board firmly in place.

### 5.5.1.3 VMIB and AAIB Wiring

There is no wiring required for proper operation of the VMIB or AAIB.

### 5.5.1.4 VMIB and AAIB LAN Connector

The VMIB and AAIB include an RJ45 for connection to a 10/100 Base-T Ethernet (IEEE 802.3) connection. The port supports auto negotiation for speed (10 or 100 Mbps) and full or half-duplex operation. If need be, the RJ45 is wired as indicated in the RJ45 pin-out chart below.

**Table 5.5.1.4-1 VMIB & AAIB RJ45 Pin-out Chart**

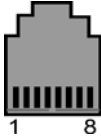
CONNECTOR	PIN	SIGNAL NAME	FUNCTION
RJ45 	4,5,7,8	Not used	
	1	TX+	Transmit Data
	2	TX-	Transmit Data
	3	RX-	Receive Data
	6	RX+	Receive Data

### 5.5.1.5 Serial Port

The VMIB an AAIB include an Audio jack connected to a Serial port. The serial port is used for diagnostic purposes. For wiring information, refer to section 5.6

## 5.5.2 VOIB (Voice over Internet protocol Board, 8 and 24channel)

The VOIB is available in two (2) models, the VOIP8 with 12 IP channels and the VOIB24 with 24 IP channels. Other than the number of channels, there are no significant differences in the VOIB8 and VOIB24. The VOIB provides the Ethernet interface for Ericsson-LG IP Phones, SIP phones and trunks, IP Networking and applications. The VOIB is used to provide packet relay for remote devices to communicate with the host and translate between the iPECS proprietary protocols and other standard protocols (H323 rev.4, SIP RFC3261).

The VOIB connects to a standard IEEE 10/100 Base-T Ethernet switch port and supports auto negotiation for speed (10Mbps or 100Mbps) and full or half-duplex operation. The VOIB supports various codecs (g.711, g.726, g.729, g.723.1), T.38 for IP FAX, and Echo Cancellation (g.168).

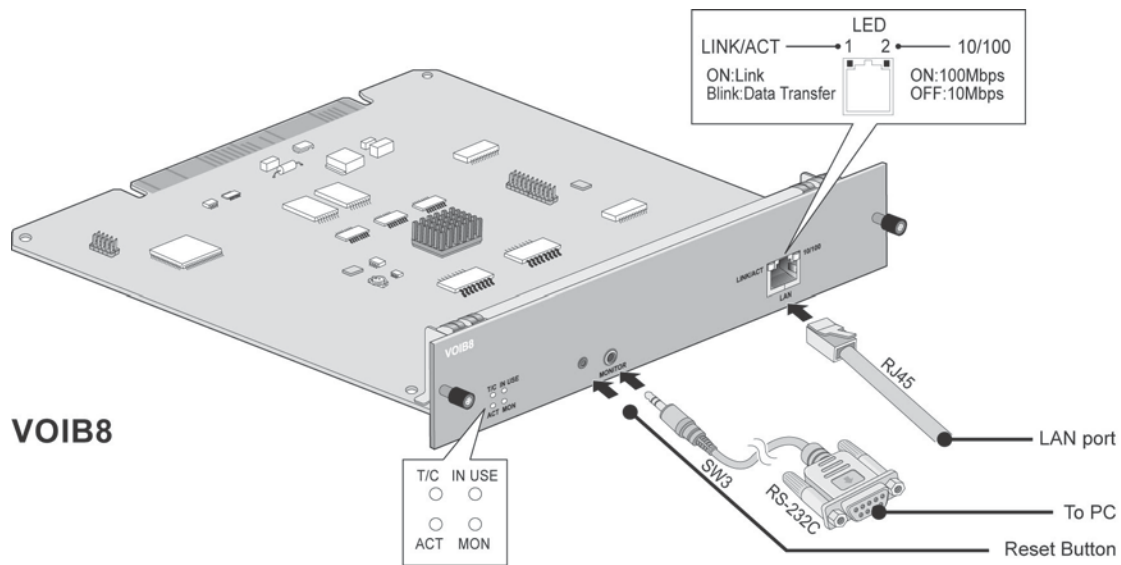

Figure 5.5.2-1 VOIB8

### 5.5.2.1 Switch and LED Functions

Table 5.5.2.1-1 Switch Functions

SWITCH	FUNCTION	REMARK
SW1	4-Pole Dip-switch (Function : not defined)	Default : Off
SW2		
SW3	Reset switch	
SW4		



**Table 5.5.2.1-2 LED Indication**

LED	FUNCTION	REMARK
LD1	VOIB Task Active (CMD/Event Processing)	Blink (Blue Color)
LD2	Trace Task Active (Line Monitor)	Blink (Blue Color)
LD3	Transcoding	On: Transcoding in use Off – Transcoding not in use
LD4	Active VOIP call (Channel in use)	On: Channel in use, OFF: All channels Idle
RJ45-LD1 (Green/Orange)	Data Link	On Link - established Blink – Data transfer
RJ45-LD2 (Yellow)	Port speed	On – 100 Mbps Off – 10 Mbps

### 5.5.2.2 VOIB Installation

The VOIB Dip switches should be set to the OFF position before installation. To install the VOIB,

- Assure Power is OFF
- Slide the VOIB in the guide rails of the desired slot.
- Tighten thumbscrews to hold the board firmly in place.

### 5.5.2.3 VOIB Wiring

The VOIB is connected to the LAN through the RJ45 connector on the front panel. The connector is terminated as a standard EIA 568B MDI (Media Dependent Interface) port.

Referring to the pin-out chart below,

- Using UTP cable, wire each VOIB TX and RX pairs to the termination point of an Ethernet switch port RX and TX pairs, respectively.

**Table 5.5.2.3-1 VOIB LAN PORT**

CONNECTOR	PIN	SIGNAL NAME	FUNCTION
RJ45 	4,5,7,8	Not used	
	1	TX+	Transmit Data
	2	TX-	Transmit Data
	3	RX-	Receive Data
	6	RX+	Receive Data

### 5.5.2.4 Serial Port

The VOIB include an Audio jack connected to a Serial port. The serial port is used for diagnostic purposes. For wiring information, refer to section 5.6.

## 5.6 Serial to Audio Cable Specification

Several board types include a serial port presented as an Audio jack. This serial port is not required for normal operation, it is only used for advanced diagnostics. Boards that include the Audio Serial connector are PRIB, BRIB2/ BRIB4, AAIB/VMIB, VOIB, and WTIB.

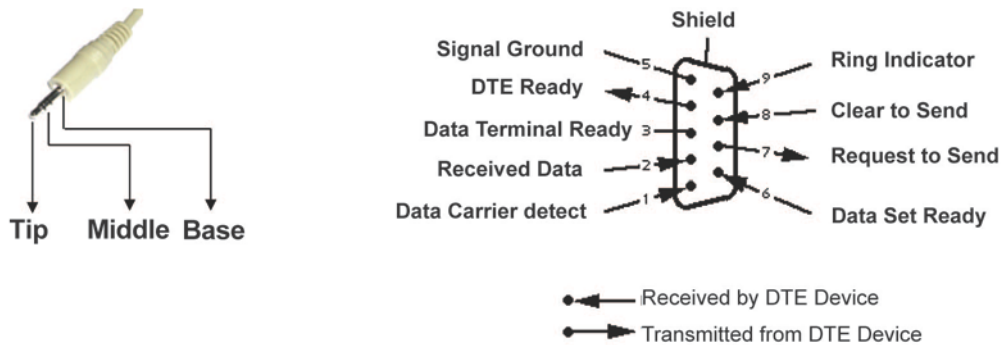

Figure 5.6-1 Audio Jack, Serial Specification

### 5.6.1 Serial to Audio Cable Wiring

Connection to the Serial port through the Audio connector is made with a Serial to Audio cable. The cable should be terminated on one end with a DB9 RS-232 connector and on the other end with an audio jack. The three (3) wires of the audio jack are wired to the DB9 as follows.

- Wire the Tip conductor of the Audio jack to pin 2 of the DB9
- Wire the Ring conductor of the Audio jack to pin 3 of the DB9
- Wire the Grd conductor of the Audio jack to pin 5 of the DB9



Figure 5.6.1-1 Audio Jack to Serial Cable

## 5.7 Cable Dressing

To provide a neat professional installation, the wiring to the KSU(s) should be dressed. The wiring cables should be bundled and tie wrapped to the KSU(s) and to the wall or rack.

### 5.7.1 Wall Mount Wiring

To dress wiring for a Wall mount installation,

1. Ensure all boards are installed and that wiring is complete.
2. Using the supplied Cable Ties, tie all wiring cables and Power cord (if desired) together in a neat bundle.
3. Using the supplied Cable Ties, tie the bundled cables to a Rack Mount bracket.
4. Dress the cable bundle under the bottom KSU and attach to the wall at regular spacing back to the wiring termination point.

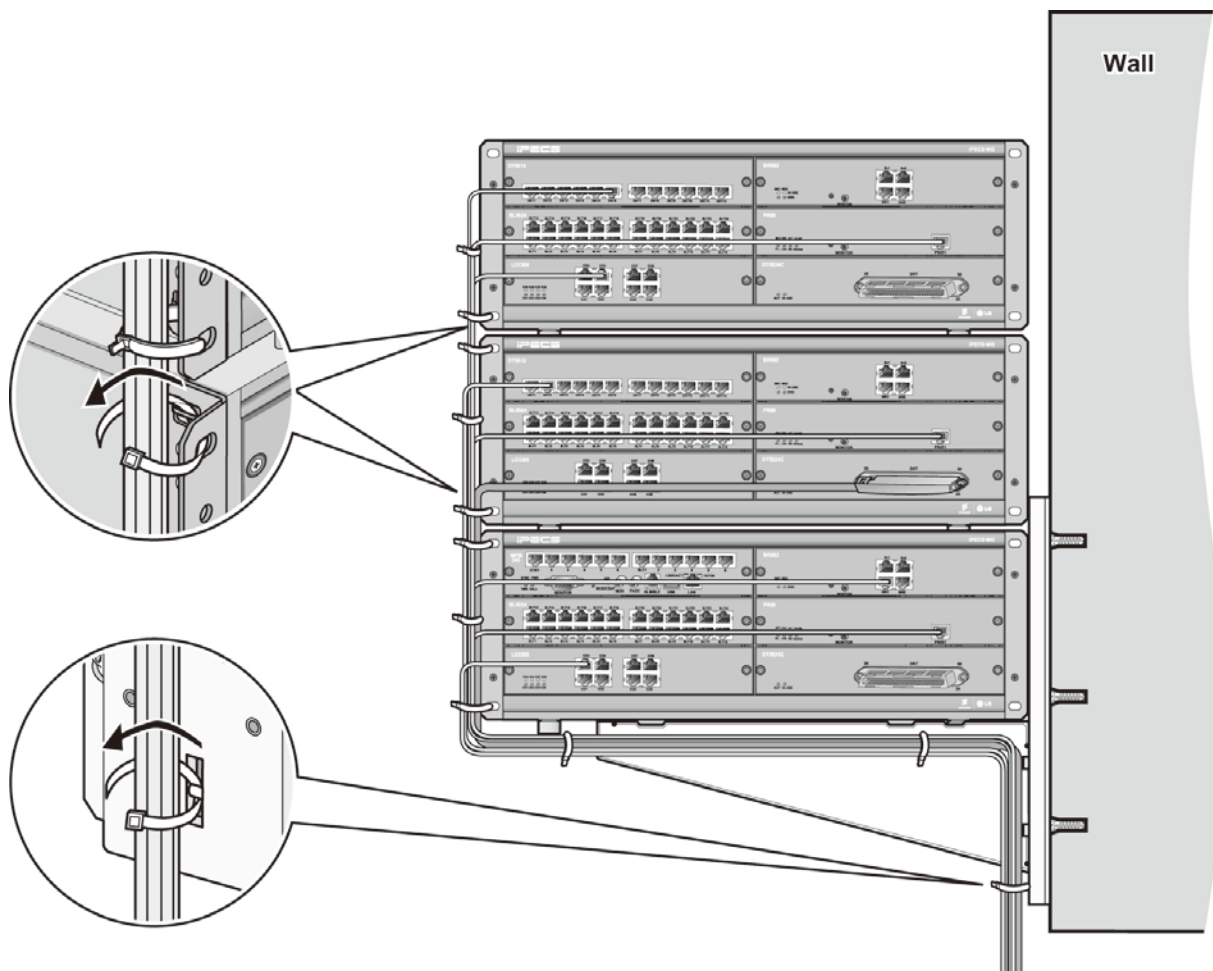

Figure 5.7.1-1 Wall Mount Wiring

## 5.7.2 Rack Mount Wiring

To dress wiring for a Rack mount installation,

1. Ensure all boards are installed and that wiring is complete.
2. Using the supplied Cable Ties, tie all wiring cables and Power cord (if desired) together in a neat bundle.
3. Using the supplied Cable Ties, tie the bundled cables using holes in the 19" Rack.
4. Dress the cable down the rack back to the wiring termination point.

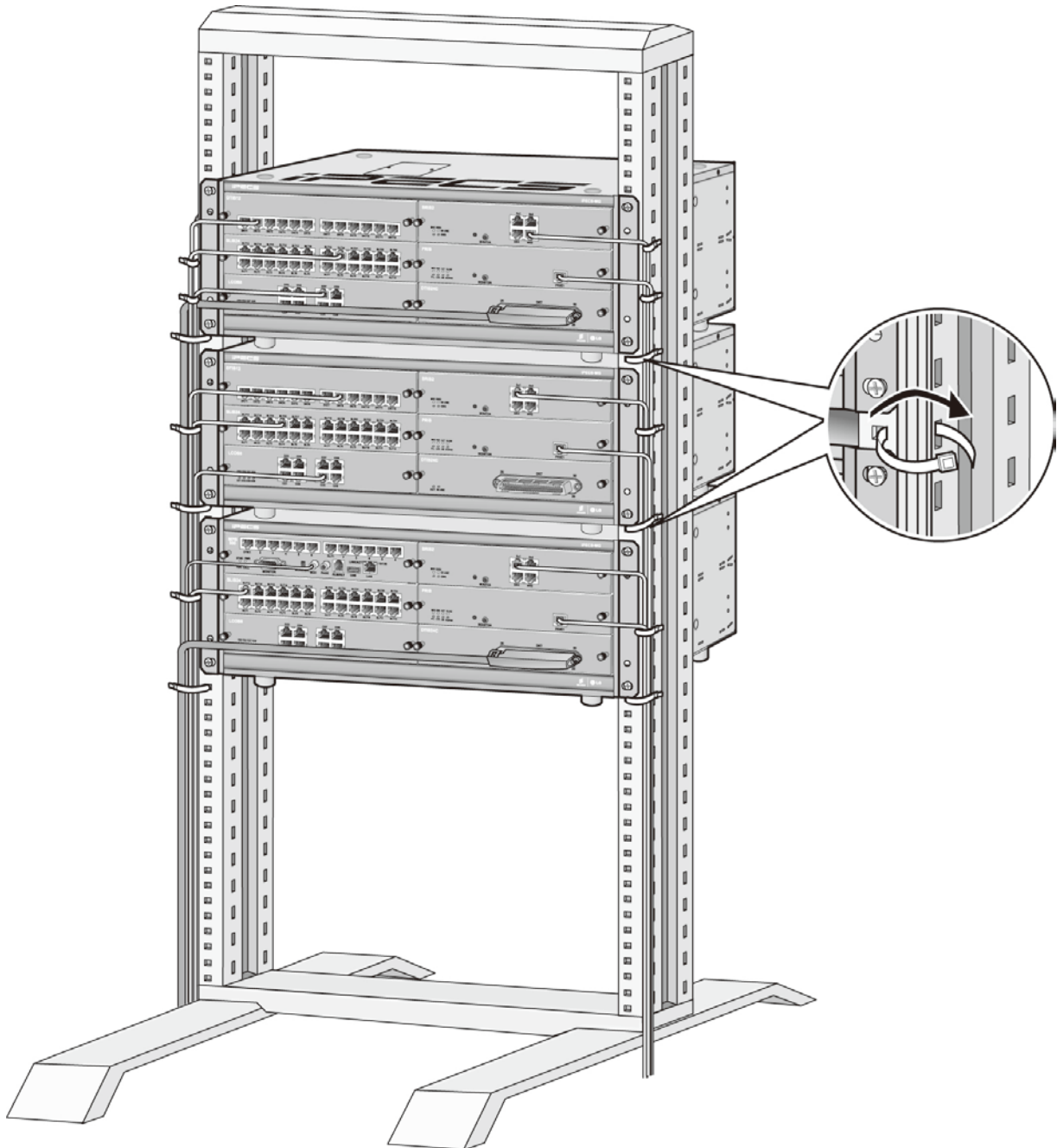

Figure 5.7.2-1 Rack Mount Cable Dressing

# 6. TERMINAL CONNECTION AND WIRING

## 6.1 Terminal and Door Phone Models

Various types of digital terminals and IP Terminals can be used with the iPECS-MG as listed in the table and shown below. Other older model digital phones may also be compatible with the iPECS-MG, check with your local Ericsson-LG representative for details.

Digital Key Telephones connect to the DSIU or a DTIB. IP Key Telephones connect to the LAN where they have access to a VOIB channel.

MODEL	DESCRIPTION
LDP-7004N	4 Flexible Button No display
LDP-7004D	4 Flexible Button w/Display
LDP-7008D	8 Flexible Button w/Display
LDP-7016D	16 Flexible Button w/Display
LDP-7024D	24 Flexible Button w/Display
LDP-7024LD	24 Flexible Button w/Large Display
LDP-7048DSS	48 Button DSS/DLS Console
LDP-DPB	Door Phone Box
LIP-7008D	8 Flexible Button w/Display
LIP-7016D	16 Flexible Button w/Display
LIP-7024D	24 Flexible Button w/Display
LIP-7024LD	24 Flexible Button w/Large Display
LIP-8002	4 Feature Button w/Display
LIP-8004D	4 Flexible Button w/Display
LIP-8008D	8Flexible Button w/Display
LIP-8012D	12 Flexible Button w/Display
LIP-8024D	24 Flexible Button w/Display
LIP-8040L	10 Flexible Button w/Large Display
LIP-8012DSS	12 Button DSS Console / Power supply
LIP-8012LSS	12 Button LSS Console / via keyset up to 2
LIP-8048DSS	48 Button DSS Console / via external up to 4
LIP-8040LSS	48 Button DSS Console w/Display via external or PoE up to 9
LIP-8002E/2AE	4 Feature Button w/Display
LIP-8008E	8 Flexible Button w/Display
LIP-8012E	12 Flexible Button w/Display
LIP-8024E	24 Flexible Button w/Display
LIP-8040E	10 Flexible Button w/Large Display
LIP-8050V	5 Flexible Button, w/Color Display & Video Camera

MODEL	DESCRIPTION
LDP-9008D	8 Flexible Button w/Display
LDP-9030D	30 Flexible Button w/Display
LDP-9048DSS	48 Button DSS Console

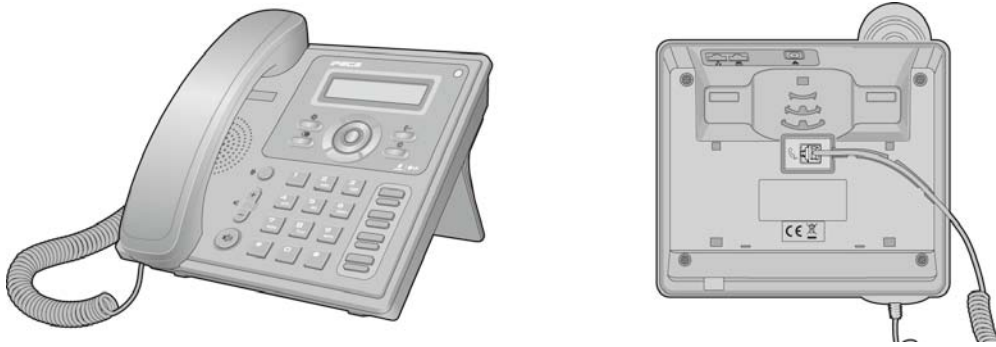

LIP-8002E/2AE



LIP-8008E



LIP-8012E



LIP-8024E



LIP-8040E

Figure 6.1-1 LIP 8000E Series Keysets



LIP-8002



LIP-8004



LIP-8008D



LIP-8012D



LIP-8024D



LIP-8040L



LIP-8050V

**Figure 6.1-2 LIP-8000 Series Keysets**

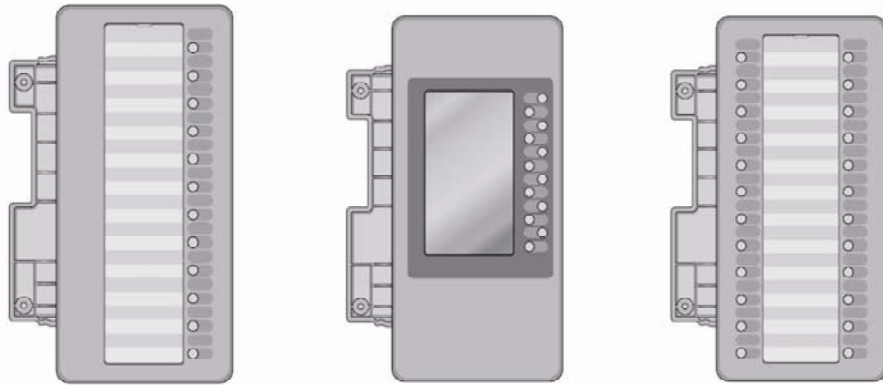

LIP-8012DSS

LIP-8012LSS

LIP-8048DSS

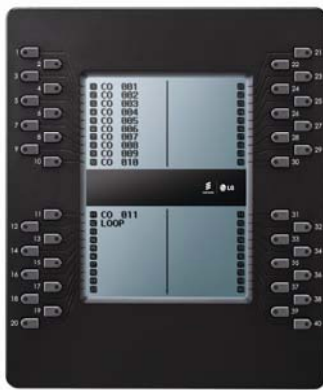

LIP-8048LSS

Figure 6.1-3 LIP-8000 Series DSS & LSS



LD-9008D



LD-9030D



LD-9048SS

Figure 6.1-4 LDP-9000 Series Keysets



### 6.1.1 Terminal Cabling Distance

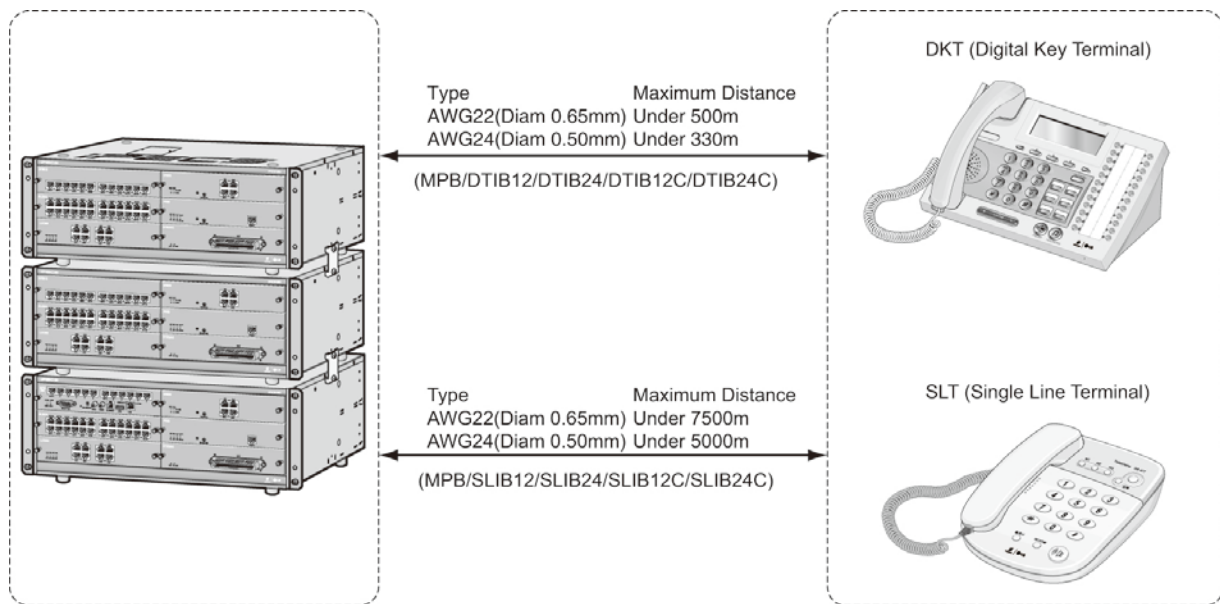

Figure 6.1.1-1 Terminal Cabling Distance

### 6.1.2 Terminal Connections



#### 6.1.2.1 DKT Wiring

The Digital Key Telephone and digital DSS Console are terminated to the 1st pair of the RJ11 located in the bottom of the DKT or Console. The wall outlet for the DKT or Console should be connected back to an appropriate DTIB or MPB DSIU DKT port.

Referring to the pin-out chart below and Figure 6.1.1-1,

- Wire the wall outlet 1st pair to the DTIB or DSIU termination point using UTP cable. Note separate wiring is required for the LDP-7048 DSS Console.
- Using the line cord provided, connect the DKT or DSS Console to the wall outlet.

Table 6.1.2.1-1 DKT Pin-out Chart

Line Cord	CONNECTOR	PIN	SIGNAL NAME
		1,2	Not used
		3	Ring
		4	Tip
		5,6	Not used

### 6.1.2.2 SLT wiring

SLTs are wired to the center pair of the RJ11, typically on the bottom or back of the SLT. The wall outlet should be connected back to an appropriate SLIB or DSIU SLT port.

Referring to the pin-out chart below and Figure 6.1.1-1,

1. Wire the center pair of the wall outlet to the SLIB or DSIU termination point using UTP cable.
2. Using the line cord provided with the SLT, connect the SLT to the wall outlet.

**Table 6.1.2.2-1 Standard SLT Pin-out Chart**

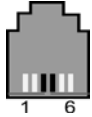
Line Cord	CONNECTOR	PIN	SIGNAL NAME
RJ11 		1,2	Not used
		3	Ring
		4	Tip
		5,6	Not used

### 6.1.2.3 LIP-7000 & LIP-8000 & 8000E Series Keypad Wiring

The iPECS-MG supports the LIP-7000 and 8000 series IP Phones. The LIP-7008D and the LIP-8004D have a single LAN port that is wired to an Ethernet switch port. All other LIP-7000 and 8000 & 8000E series phones shown here have two (2) Ethernet ports, a LAN port and a PC port. The LAN port is connected to an Ethernet switch port and the PC port is connected to the LAN port of a PC. The LIP phones are wired to any 10/100 Base-T Ethernet switch port with access to a VOIB channel. The LIP phones can be powered from a POE compatible Ethernet switch port or using the AC/DC Adaptor-K.

Referring to Figure 6.1.2.3-1 and the IP Phone pin-out chart below,

- Wire the RX and TX pins from the RJ45 Wall outlet, or equal, for the IP Phone to the appropriate Ethernet switch termination point using Cat 5 UTP cable. The maximum wire length between the IP Phone and the Ethernet switch port is 100m or 328 feet.
- Use the RJ45 terminated cable provided with the phone to connect the IP Phone to the Wall outlet.
- Connect the PC port to a PC LAN port using a CAT 5 cable terminated on each end with an RJ45 connector.
- If not using a POE switch port, connect the DC connector of an AC Adaptor-K to the DC input on the bottom of the IP Phone and plug the AC plug of the AC adaptor in to a 100-240 VAC outlet.

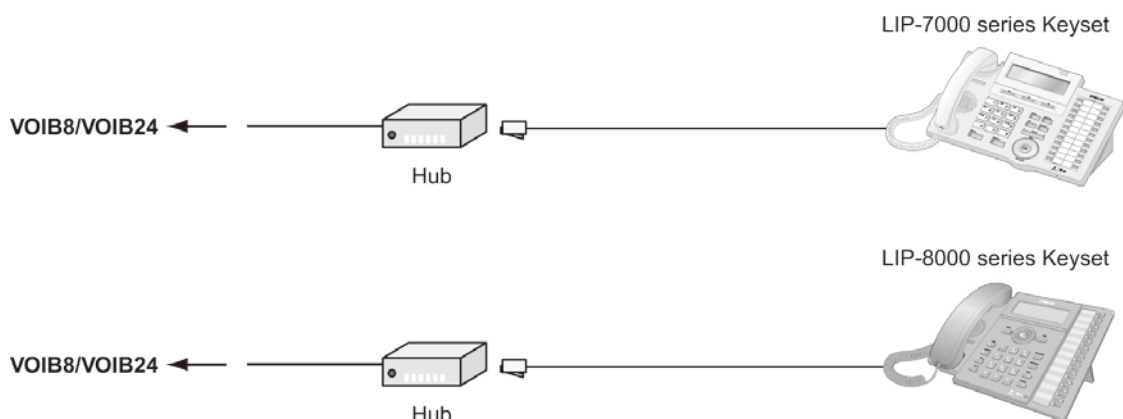

**Figure 6.1.2.3-1 LIP Phone Connection**

**Table 6.1.2.3-1 IP Phone Pin-out Chart**

CONNECTOR	PIN	SIGNAL NAME	FUNCTION
RJ45 	4,5,7,8	Not used	
	1	TX+	Transmit Data
	2	TX-	Transmit Data
	3	RX-	Receive Data
	6	RX+	Receive Data

### 6.1.3 LDP Door Phone Box

The iPECS-MG supports the LDP DPB, digital Door Phone Box. The Door Phone Box can place a call to assigned stations and a station can answer the Door Phone Box call. If configured, the station user can activate a door-lock release mechanism to allow entry.

#### 6.1.3.1 Door Phone Box Installation

The Door Phone Box can be wall mounted in a protected environment; the DPB is not intended for exterior application. To wall mount the LDP-DPB,

- Locate the mounting position for the Door Phone Box,
- Mark position for two (2) screws
- Drill holes for two (2) plastic anchors
- Insert screws and tighten leaving about ¼ inch exposed.
- Align the screw holes in the back of the LDP-DPB with the screws and slide down to lock in place. It may be necessary to remove the box and loosen or tighten the screws for a secure fit.

#### 6.1.3.2 Door Phone Box Wiring

The Door Phone Box is wired using screw terminals in the box. The terminals are wired to any available DKT port except for the first DKT port.

- Referring to Figure 6.1.3.2-1 and the pin-out chart below,
- Loosen the screw holding the Door Phone Box cover.
- Loosen the two (2) screw terminals.
- Using a UTP cable terminated on one end with an RJ11, strip approximately ¼ inch of insulation from the center pair at the un-terminated end of the wire.
- Insert the DKT Tip in one terminal and the DKT Ring.
- Tighten the screws to connect and securely fasten the wires.
- Plug the terminated end of the wire into a standard wall outlet with an RJ11.
- Wire the wall outlet 1st pair to the DTIB or DSU termination point using UTP cable.

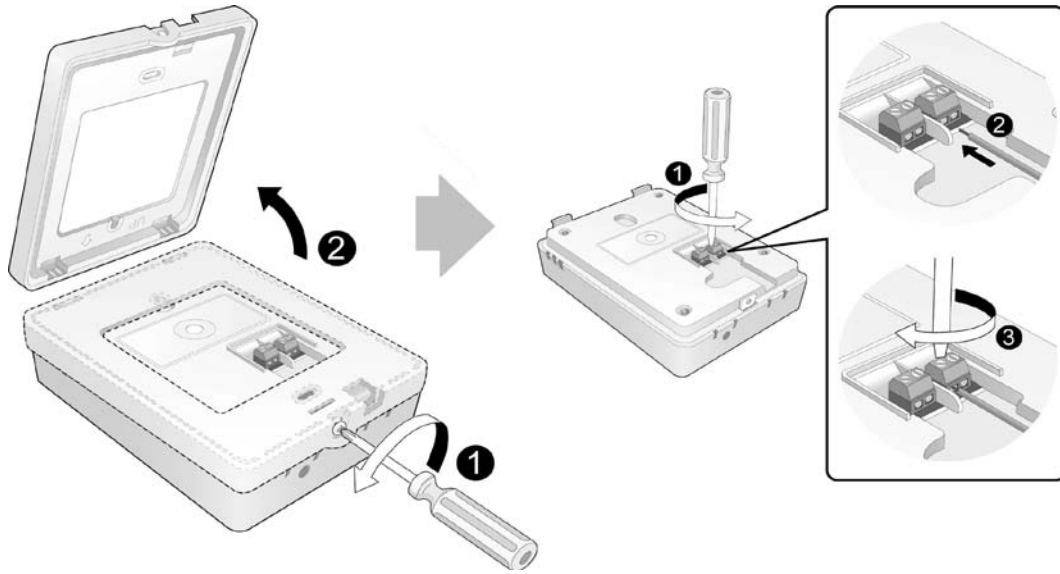



Figure 6.1.3.2-1 Door Phone Box Wiring

Table 6.1.3.2-1 LDP-DPB Pin-out Chart

Line Cord	CONNECTOR	PIN	SIGNAL NAME
RJ11 		1,2	Not used
		3	Ring
		4	Tip
		5,6	Not used

## 6.1.4 DSS/BLF Console Installation & Wiring

### 6.1.4.1 LDP-7048 DSS Install

The digital LDP-7048 DSS/BLF Console is provided with a phone-mounting bracket, used to fasten the Console to the phone securely. To attach the fastener,

- turn the Console and phone upside down,
- place the fastener in position,
- insert and tighten screws. Caution, do not over-tighten as this may damage the plastic phone housing.

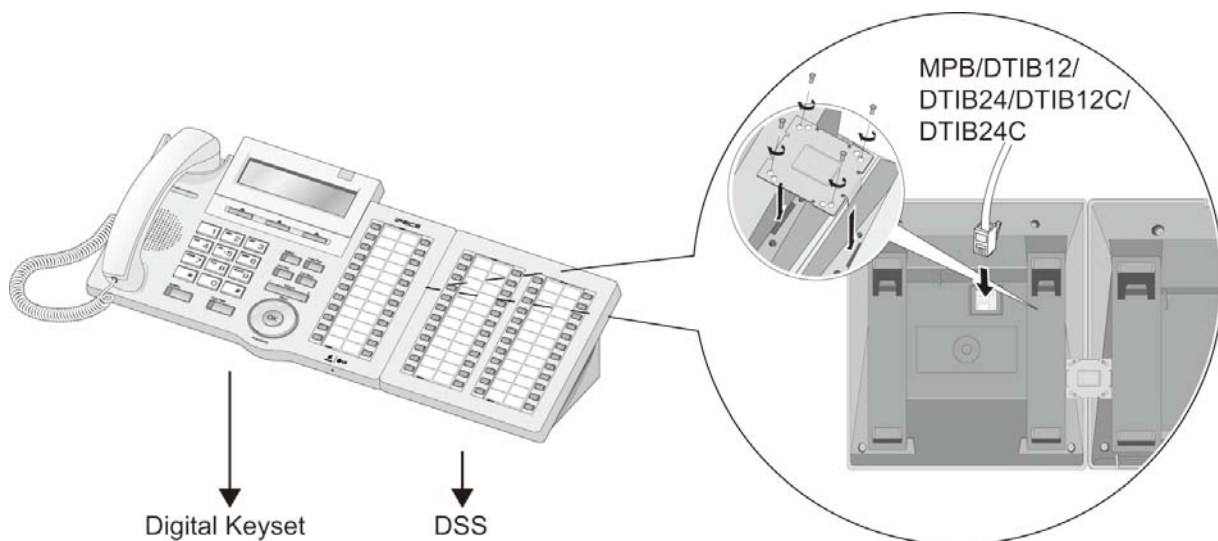

Figure 6.1.4.1-1 LDP-7048 and LIP-7048 Console Install

### 6.1.4.2 LDP-7048 and LIP-7048 DSS Console Wiring

The LDP-7048 DSS Console is wired as a normal Digital Key Telephone to a separate port of a DISU or DTIB, refer to section 6.1.2.1. The LIP-7048 DSS Console is wired as a normal LIP-7000 series IP Phone, refer to section 6.1.2.3. The LIP-7048 DSS Console must be powered by a POE compatible Ethernet switch port or the AC/DC adaptor-K for the LIP Phones.

### 6.1.4.3 LIP-8000 DSS Installation and Wiring

The LIP-8000 Series DSS/BLF Console is available in three (3) models 12 button w/paper labels (LIP-8012DSS), 12-button w/LCD (LIP-8012LSS), and 48-button w/paper labels (LIP-8048DSS). Up to four (4) consoles can be connected to an LIP-8000 & 8000E series phone using the serial ribbon cable from the console. A maximum two (2) LCD DSS Consoles can be supported and, when more than two consoles are connected, one must be the 48-button Console. In all cases, the 48-button Console must be powered by the AC/DC Adaptor-K.

Referring to install an LIP-8000 series DSS Console,

- turn the LIP phone and DSS Console upside down
- remove the rubber plug in the LIP phone protecting the DSS serial cable connector.
- insert the flat ribbon cable from the DSS Console into the connector in the LIP phone.
- insert and tighten two (2) screws through the DSS Console mounting flange into the LIP phone. Caution, do not over-tighten the screws as this may damage the LIP phone housing.
- for additional DSS/BLF Consoles, repeat the procedure connecting one console to the previous console. A maximum of three consoles can be supported by an LIP-8000 series phone.
- for each LIP-8048DSS and LIP-8040LSS, insert the DC plug of an AC Adaptor-K to the DC input of the DSS Console and plug the AC plug into an appropriate (110/240 VAC) outlet.

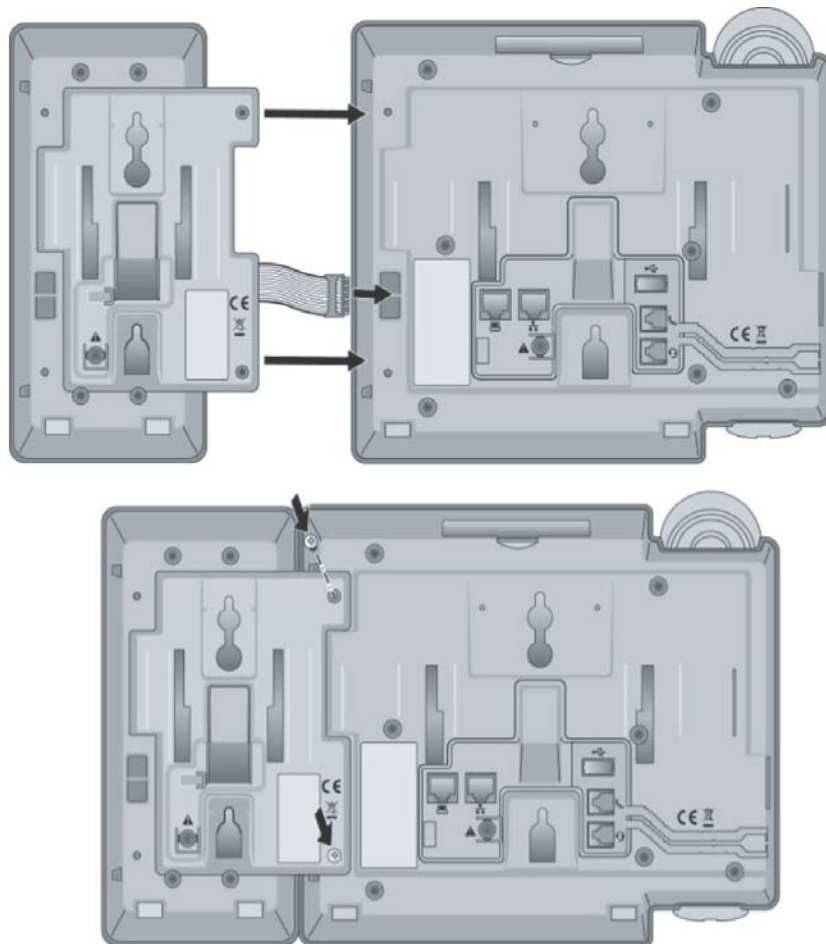

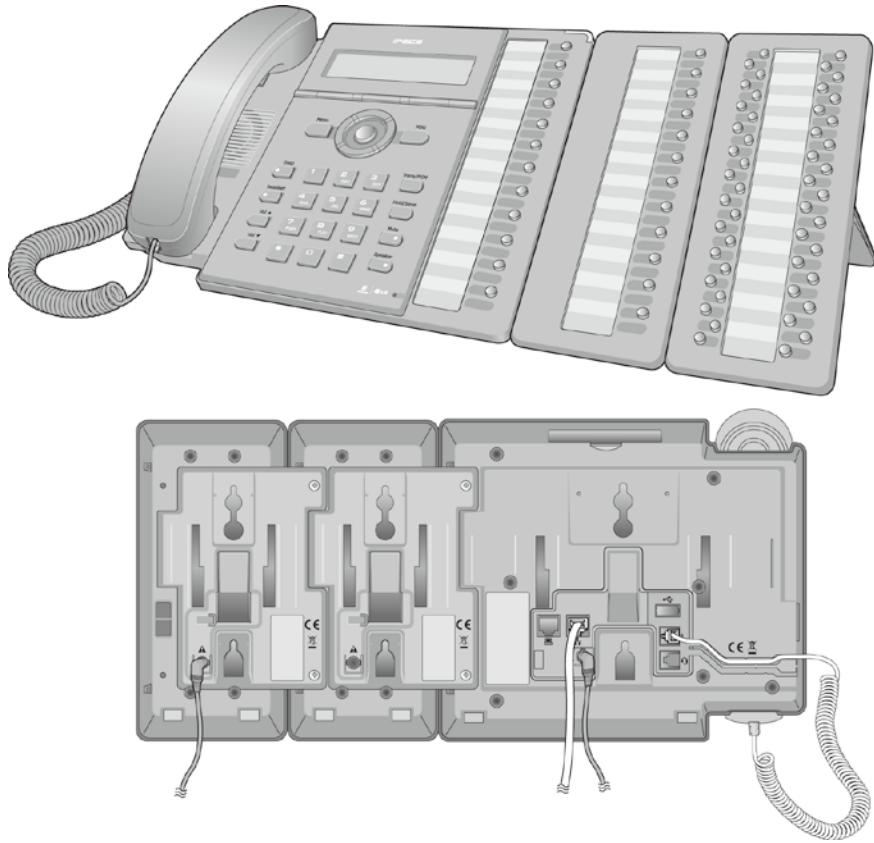

Figure 6.1.4-1 LIP-8000 DSS Installation (12DSS + 48DSS)

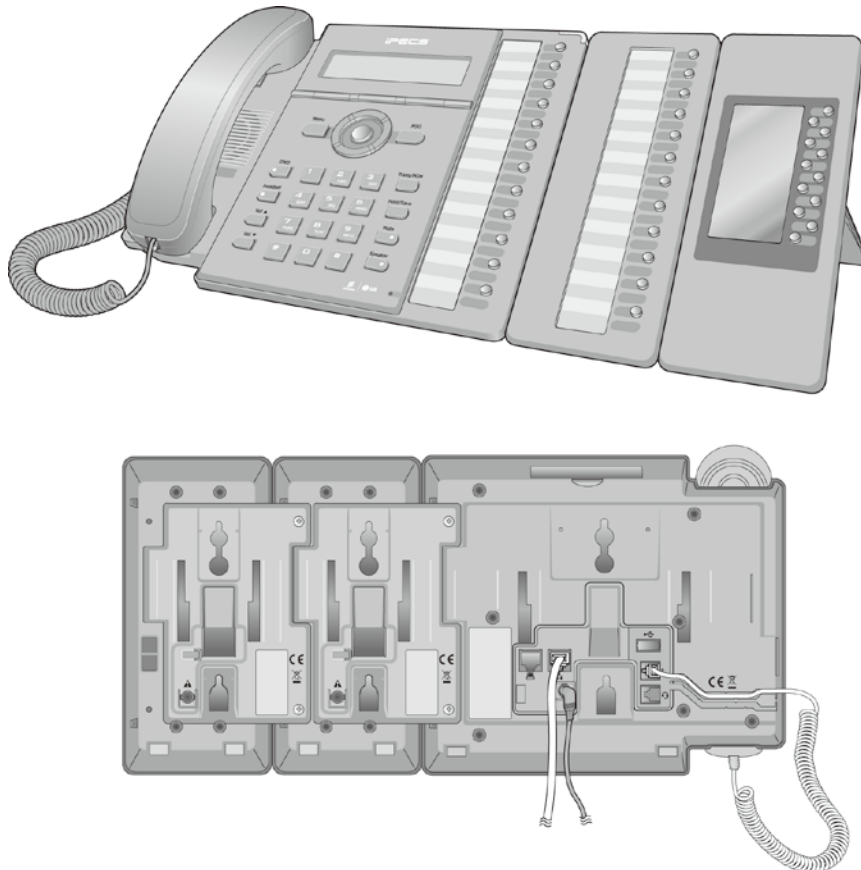

Figure 6.1.4-2 LIP-8000 DSS Installation (12DSS + 12LSS)

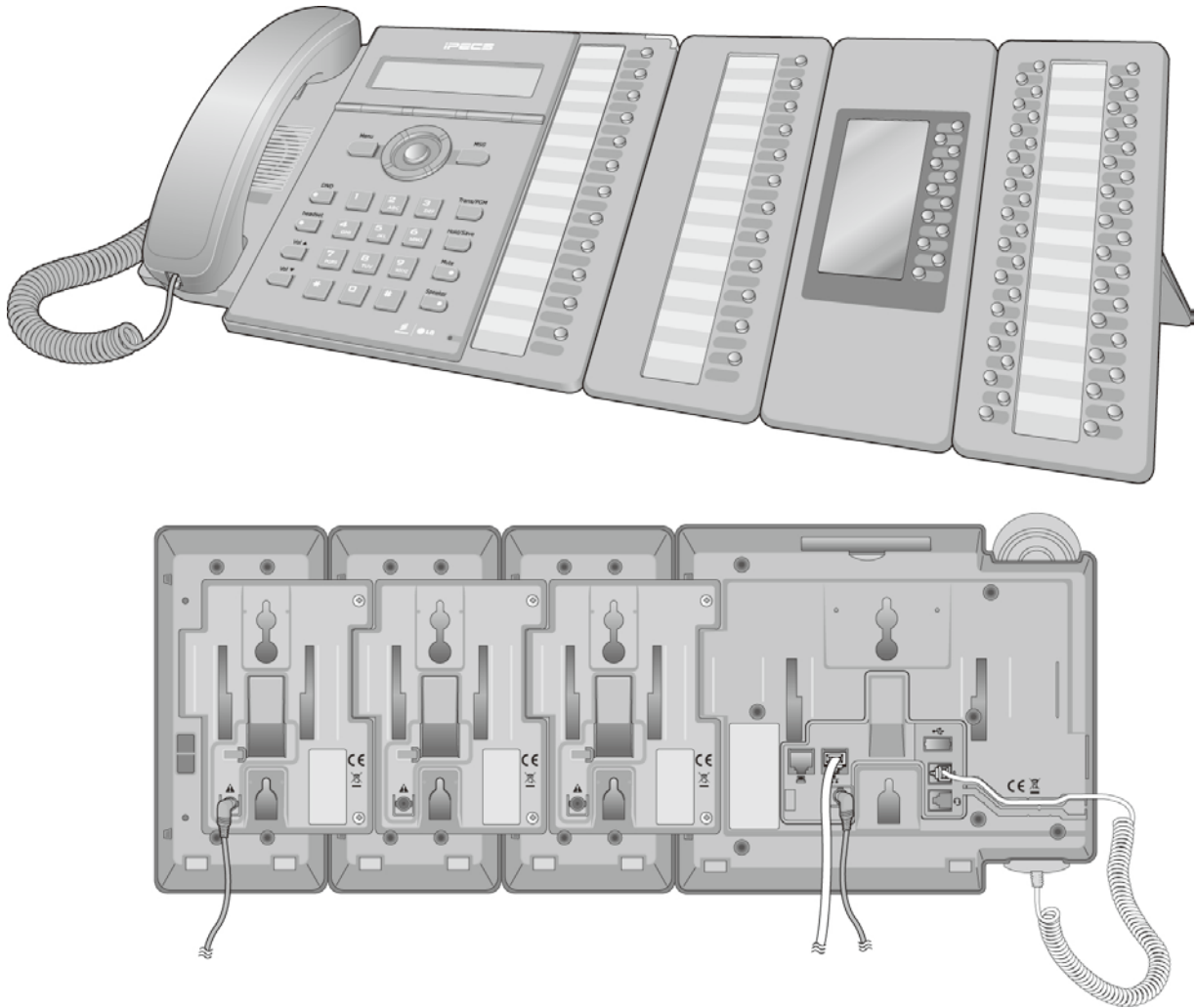

Figure 6.1.4-3 LIP-8000 DSS Installation (12DSS + 12LSS+48DSS)



## 6.1.5 Wall Mount

### 6.1.5.1 LDP-7000 and LIP-7000 Wall Mounting

The LDP-7000 or LIP 7000 series phones can be mounted on the wall using the appropriate Wall Mount Kit. The Wall Mount Kit is installed as described below and shown in Figure 6.1.5.1-1.

- Using the appropriate Wall Bracket, mark and drill two (2) 7 mm holes for the plastic wall anchors provided.
- Insert the two (2) anchors into the holes and insert and tighten the 2 screws leaving about 6 mm (¼-inch) exposed. Refer to Figure 6.1.5.1-1.
- Connect one end of a short cable terminated in RJ11s or RJ45s to the LDP-7000 or LIP-7000 series Phone, respectively, and then connect the other end in a wall jack.
- Mount Wall Mount bracket on the phone.
- Slide the Wall Mount bracket over the screws, if loose, tighten the screws slightly and mount the Wall Mount bracket again.
- Insert the Wall Mount handset hook to prevent the handset from slipping when wall mounted. For the LIP-7000 series, the Handset hook is molded as part of the Wall Mount bracket as shown in Figure 6.1.5.1-1.

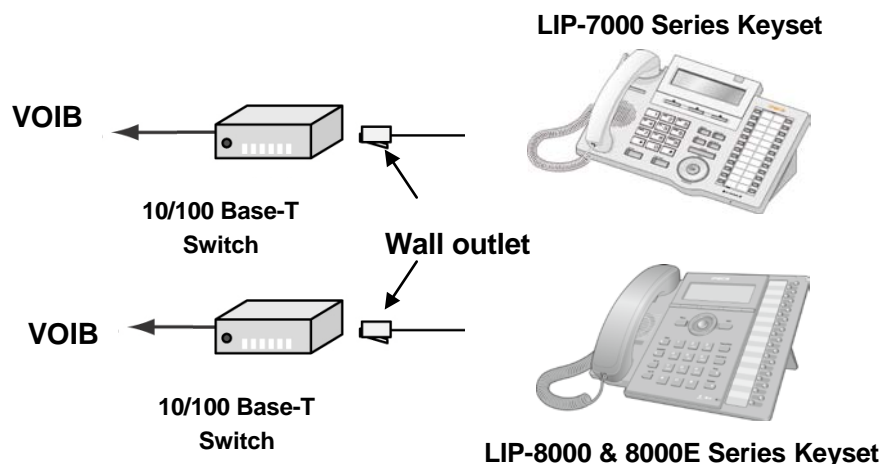

Figure 6.1.5.1-1 LIP-7000 Wall Mount Installation

### 6.1.5.2 LIP-8000 & 8000E Wall Mounting

The LIP-8000 & 8000E series phones incorporate wall mount into the base of the phone housing. Using the instructions below and Figure 6.1.5.2-1, wall mount the LIP-8000 & 8000E phone.

- Mark and drill two (2) 7mm holes for plastic wall anchors.
- Insert the two (2) anchors into the holes and insert and tighten the 2 screws leaving about 2.5 mm (1/8-inch) exposed. Refer to Figure 6.1.5.2-1.
- Slide the LIP-8000 phone over the screws and assure the phone is secure. Note it may be necessary to remove the phone and tighten or loosen the screws for a secure mounting.

- Remove the Handset hook from the phone as shown in the figures below. Reverse the hook and re-install in the LIP-8000 & 8000E phone so that the hook catches the groove in the handset receiver.

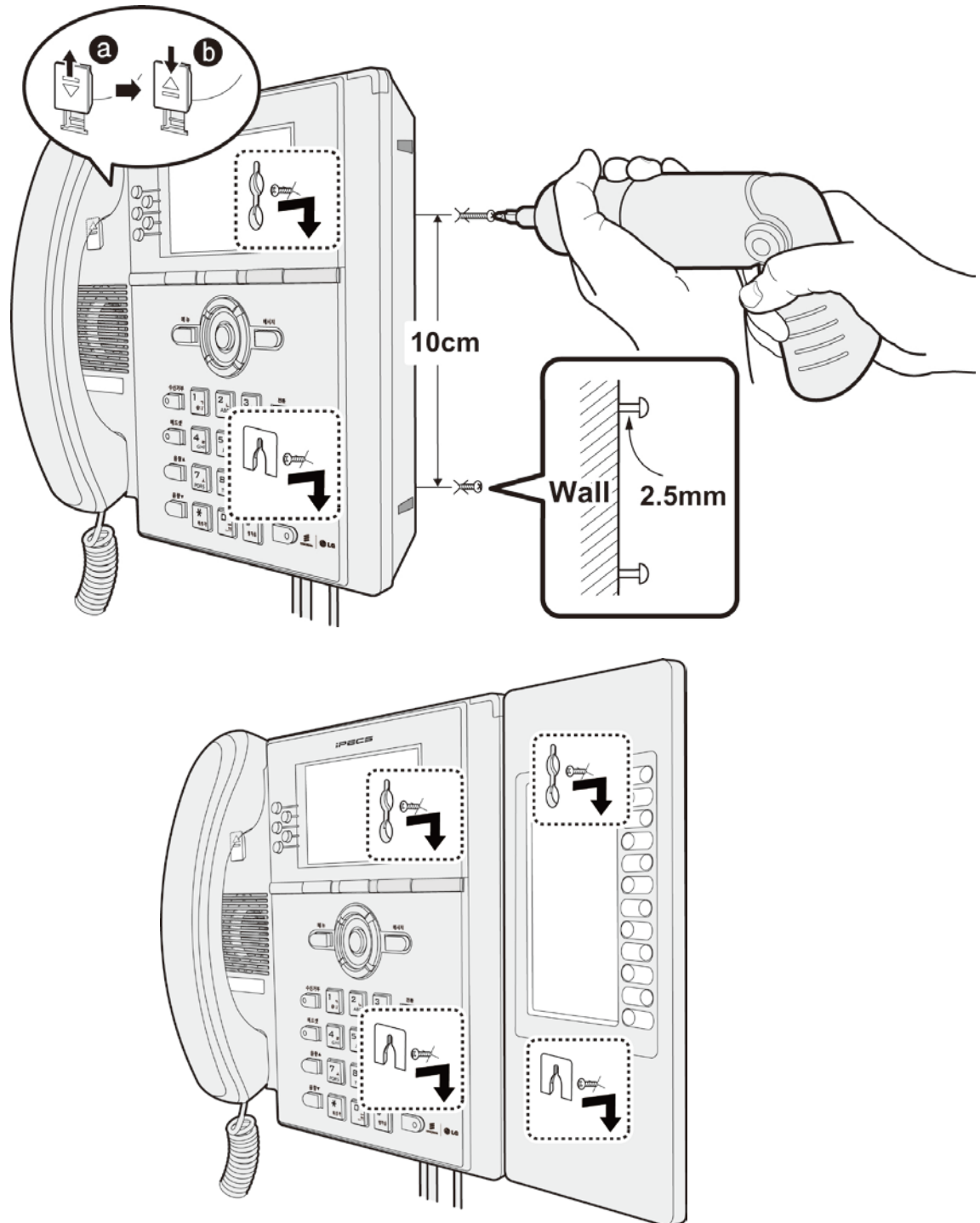

**Figure 6.1.5.2 1 LIP-8000 & 8000E Wall Mount Installation**

DSS consoles can be wall mounted with the LIP-8000 & 8000E series phone after properly connecting the Console to the LIP-8000 phone as described in section 6.1.4.3.

# 7. STARTING THE IPECS-MG

## 7.1 Initializing Databases

After completing installation, it is highly recommended that the iPECS-MG System database be initialized to default values for the local Country Code. During the initialization sequence, the System will identify all the installed resources and assigns port numbers to the each port on each board based on the order of appearance starting at the 1st DKT port on the MPB DSIU then the SLT ports 1 to 6 of the DSIU. Port numbers are then assigned to the ports of slot 1 to 6 then to slots 1 to 6 of the first EKSU and finally, the 2nd EKSU slot 1 to 6. Port numbers are assigned separately for different 'Types' of boards,

- Extension boards including the DSIU, DTIB, WTIB, SLIB
- CO boards including the LCOB, E1/PRI, T1/PRI, VOIB
- Voice Service boards including the VMIB, AAIB

In the initialization process, in addition to setting the database to default, scratched pad memory is cleared and any Voice Mails are erased along with any Greetings or Name recordings.

- To initialize the database, the System must be powered up with the Mode switch On.
- Place the MPB Mode switch in the OFF position.
- Assure the AC power cord for each KSU is plugged into an appropriate AC outlet, grounded, 3-prong.
- Turn on the power switch of each of the Expansion KSU.
- Turn on the power switch of the Basic KSU.
- After restart place the Mode switch in the ON position

After several moments various front panel LEDS will illuminate indicating the power-up sequence. The LEDs of the MPB will assume the normal operation illumination as shown in the chart below. It may take a short period, 120 seconds for all the boards to achieve full initialization and normal LED indications.

**Table 7.16.1.5-1 MPB LED Indications**

LED	DESCRIPTION
LD1 (Blue), TMR	Timer, Periodic Toggle — ON, 100msec; OFF, 100msec.
LD2 (Blue), CALL	Call Task Status — ON, Call task activated; OFF, Call Task idle
LD3 (Blue), SYNC	External ISDN board (PRI or BRI) Clock synchronization ON: PLL circuit activation by External Clock from ISDN Board iPECS-MG will operate based on external ISDN clock (refer to "NOTE"). OFF: PLL activation by Internal Clock iPECS-MG will operate based on the internal clock.
LD4 (Blue), PWR	System DC Power ON Indication – ON, Power ON; OFF, Power OFF

Once the MPB has assumed normal operation, the Country Code should be verified and, if need be, changed as described below and in the iPECS Admin Manuals.

- Locate Station 100, this should be the DKT attached to the 1st station port of the MPB DSIU.
- Press the TRANS/PGM button, the On/Off or Speaker LED illuminates.
- Dial '\*' and '#', confirmation tone is heard from the speaker.
- Press the TRANS/PGM button again to receive confirmation tone.
- Dial 100, confirmation tone is received.
- Press Flexible button 1, the display indicates the Country Code.
- If the Country Code is correct, press the On/Off or Speaker button and change the Mode switch to ON. The System is now ready for programming; refer to the iPECS-MG Admin Manuals.

If the Country Code is not correct,

- Enter the correct Country Code, refer to the Nation Code chart below.
- Press the **[HOLD/SAVE]** button to store the entry.

**Table 7.1-2 Nation Code Listing**

NATION	CODE	NATION	CODE	NATION	CODE
Argentina	54	Honduras	504	Peru	51
Australia	61	Hong Kong	852	Philippines	63
Azerbaijan	994	India	91	Poland	48
Bahrain	973	Indonesia	62	Portugal	351
Bangladesh	880	Iran	98	Qatar	974
Belarus	375	Iraq	964	Rumania	40
Belgium	32	Ireland	353	Russia	7
Bolivia	591	Israel	972	Saudi Arabia	966
Brazil	55	Italy	39	Senegal	221
Brunei	673	Japan	81	Singapore	65
Cameroon	237	Jordan	962	South Africa	27
Chile	56	Kenya	254	Spain	34
China(P.R.C)	86	Korea	82	Sri Lanka	94
Colombia	57	Kuwait	965	Swaziland	268
Costa Rica	506	Kyrgyzstan	996	Sweden	46
Cyprus	357	Liberia	231	Switzerland	41
Czech(Slovak)	42	Libya	218	Tajikistan	992
Denmark	45	Luxembourg	352	Telkom	*27
Ecuador	593	Malaysia	60	Telstra	*61

<b>NATION</b>	<b>CODE</b>	<b>NATION</b>	<b>CODE</b>	<b>NATION</b>	<b>CODE</b>
Egypt	20	Moldova	373	Thailand	66
El Salvador	503	Malta	356	Tunisia	216
Ethiopia	251	Mexico	52	Turkey	90
Fiji	679	Monaco	377	Turkmenistan	993
Finland	358	Morocco	212	U.A.E.	971
France	33	Myanmar(Burma)	95	Ukraine	380
Gabon	241	Netherlands	31	United Kingdom	44
Georgia	995	New Zealand	64	Uruguay	598
German	49	Nigeria	234	U.S.A	1
Ghana	233	Norway	47	Uzbekistan	998
Greece	30	Oman	968	Venezuela	58
Guam	671	Pakistan	92	Vietnam	84
Guatemala	502	Panama	507	Y.A.R.	967
Guyana	592	P.N.G	675		
Haiti	509	Paraguay	595		

After changing the Country Code, you must reset the System,

- Press the **[TRANS/PGM]** button
- Dial 499
- Press Flexible button 2
- Press **[HOLD/SAVE]** button.

The System will proceed to initialize the database with the new Country Code. Once initialized and operating normally, change the position of the MPB mode switch to the ON position. With initialization complete, the iPECS-MG can be configured to meet the needs of the business and individual user. For detailed information on programming the iPECS-MG, refer to the iPECS-MG Admin Manuals.

## 8. TROUBLESHOOTING

PROBLEM	CAUSE/SYMPTOM	SOLUTION
System power failure	AC Power Fail	Assure Fuse/Breaker is operational. Assure AC Power is delivered to AC outlet. Check the PSU Fuse Check LD21, LD22 on the backplane, if out, replace the PSU.
	Check +5V, +30V Fail	Verify MPB is installed. Assure no short circuits on any board by removing one board at a time from the KSU.
	LD4 LED OFF on the MPB	Check DC Output status on MB
System does not operate	Short circuit in some board(s)	Check the connection of each board with the MPB by removing one board at a time from the KSU.
	Bad board connection	
	System database corrupted	Press the Reset button when the Dipswitch (SW1 for database protection) is in the default position.
	MPB operation	Check MPB status and SW1 position
DKT does not operate	Bad DTIB circuit	Replace the malfunctioning board.
	Bad connection between the DSIU /DTIB and DKT Terminals	Check the connection between the board and the DKT. Assure proper wiring terminations. Repair any broken connection between the Board and DKTs.
	Installation Distance of DKT and System	Assure the distance between the board and DKT does not exceed specs.
	Bad DKT	Plug the DKT into another extension port that has been verified as working. If the DKT still does not work properly, replace the DKT.
SLT does not operate	Bad DSIU/SLIB	Exchange the Extension board.
	Bad connection between the DSIU/SLIB port and SLT	Check that the connection between the board and the SLT.
CO line operation failure	CID/Tone Detection Fail	Check CID type assigned for CO line Assure CID provided from carrier. If one CO Line or board, replace the board.
	Bad connection	Check all connections.
Expansion KSU does not operate	Power ON sequence	Use the proper power-up sequence. Turn on all EKSUs then power on the Basic KSU Press the MPB Reset button to reset the system.
	Expansion cable connection	Check Expansion cable to verify the connection and condition.
	Expansion KSU PSU is not providing power.	Assure that the BKSU power is ON and the MPB is installed. Assure the PSU is plugged in, that the AC power is delivered to the outlet, and the Fuse/Breaker is operational.

<b>PROBLEM</b>	<b>CAUSE/SYMPTOM</b>	<b>SOLUTION</b>
Noise on External MOH and Paging port	Induced noise on the wire between the System and the amplifier	Assure the wiring is not run near equipment that generates high RF interference. Assure there are no coils in the wiring. Use shielded pair wiring and ground the shield.
	Excessive input level from the external music source	Decrease the output level of the external music source.

## **9. APPENDIX. USEFUL INFORMATION**

### **Open Source Software Notice**

This following GPL (General Public License) software used in this product are subject to the GPL License Agreements.

You can obtain a copy of the GPL licenses from Ericsson-LG Web Site (<http://www.ericssonlg.com>).

GPL License:

1. armboot
2. linux
3. busybox
4. dhcpcd
5. u-boot

Ericsson-LG offers to provide source code to you on CD-ROM for a charge covering the cost of performing such distribution, such as the cost of media, shipping and handling upon e-mail request to Ericsson-LG at. : [opensource@ericssonlg.com](mailto:opensource@ericssonlg.com).

This offer is valid for a period of three (3) years from the date of the distribution of this product by Ericsson-LG